

SIRUBA®

銀爺牌工業用縫紉機

INDUSTRIAL SEWING MACHINE

D007

零件圖 PARTS LIST

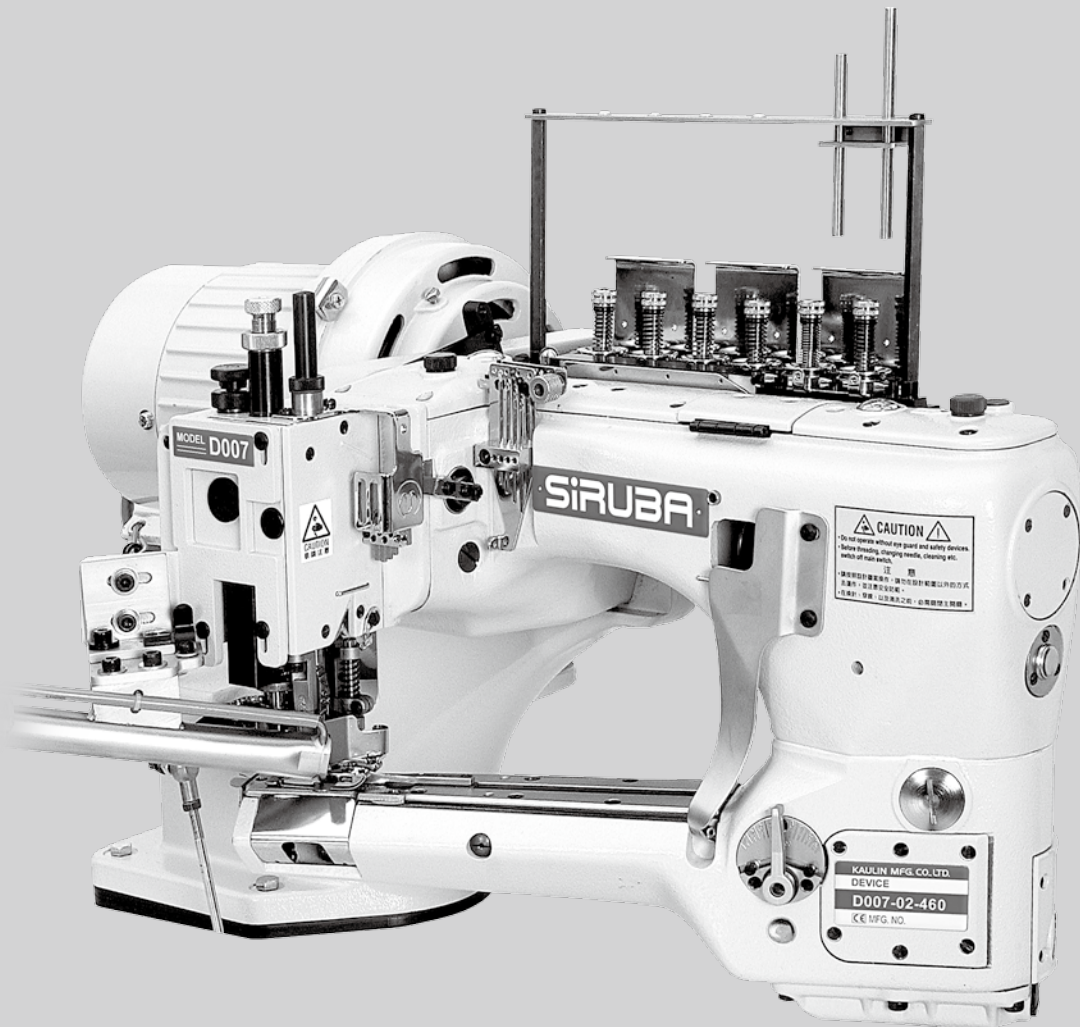

CE



高林股份有限公司
KAULIN MFG. CO., LTD.

CONTENTS

目次

MISCELLANEOUS COVERS(1)	機殼機構(1)	1
MISCELLANEOUS COVERS(2)	機殼機構(2)	2
MISCELLANEOUS THREAD EYELETS	過線機構	3
MISCELLANEOUS BUSHINGS	套管機構	4
MAIN SHAFT DEIVING MECHANISM	上主軸與針棒機構	5
ONE SIDE CUT PRESSER FOOT MECHANISM	單切壓腳與壓腳驅動機構	6
UPPER KNIFE CARRIER AND HOOK DRIVING MECHANISM	上切刀及上勾針驅動機構	7
LOOPER DEIVING MECHANISM	下勾針驅動機構	8
FEED DEIVING MECHANISM	送料具驅動機構	9
FEED DEIVING CONTROL MECHANISM	送料具調節機構	10
LUBRICATING MECHANISM	給油機構	11
DOBLE SIDE CUT PRESSER FOOT MECHANISM	雙切壓腳機構	12
/SV/ DEVICE	伺服馬達機構	13
/AT/ DEVICE	氣動抬壓腳機構	14
/ET/ DEVICE	電動抬壓腳機構	15
/AW/ DEVICE, C.SET (SELECT DEVICE)	外接式吸布屑組-AW1 (選擇配備)	16
THREAD STAND	線架組	17
/CL/ DEVICE	普通馬達機構	18
ATTACHMENT BOX	附件盒	19
ACCESSORIES	附件箱	20
/CL//AW/ DEVICE, C.SET (SELECT DEVICE)	外接式吸布屑組-AW2 (選擇配備)	21
EXCLUSIVE PARTS	貼條專用零件	22
STITCH LENGTH SPECIFICATION	針距規格表	23

Ref. No.	Parts No.	Description	品 名	Amt. Req.
1	P1-1	Crank Chamber Cover	曲軸室上蓋	1
2	P1-2	Crank Chamber Cover Gasket	曲軸室墊片	1
3	P1-3	Screw(11/64-40X11)	螺絲	5
4	P1-4	Screw(M12-1.75X9)	螺絲	2
5	P1-5	O-Ring	O型橡膠環	2
6	P1-6	Oil Sight Top Window	上油鏡	2
7	P1-7	Screw (9/64-40X11.3)	螺絲	10
8	P1-8	Top Cover (Middle)	上蓋(中)	1
9	P1-9	Screw (11/64-40X6.5)	螺絲	2
10	P1-10	Nut	螺帽	2
11	P1-11	Screw (9/64-40X5.6)	螺絲	4
12	P1-12	Top Cover (Middle) Spring	上蓋(中)彈簧	1
13	P1-13	Nut	螺帽	2
14	P1-14	Top Cover (Middle) Hinge	上蓋板(中)活動板	1
15	P1-15	Screw (9/64-40X6)	螺絲	7
16	P1-16	Top Cover (Front)	上蓋(前)	1
17	P1-17	Rivet	鉚釘	2
18	P1-18	Top Cover (Front) Gasket	上蓋墊片(前)	1
19	P1-19	Screw (5/16-24X32)	螺絲	3
20	P1-20	Washer	墊片	3
21	P1-21	Emblem	銘牌	1
22	P1-22	Warning Sticker	警告貼紙	1
23	P1-23	Machine Frame End Cover Gasket	防油墊片	1
24	P1-24	Machine Frame End Cover	防油蓋	1
25	P1-25	Looper Lever Shaft Cover Gasket	防油墊片	1
26	P1-26	Looper Lever Shaft Cover	防油蓋	1
27	P1-27	Screw (9/64-40X5)	螺絲	10
28	P1-28	O-Ring	O型橡膠環	3
29	P1-29	Drain Hole Screw (3/8-24X8)	止油螺絲	1
30	P1-30	Plug Screw(M14-1X4)	止油螺絲	2
31	P1-31	Screw (1/4-28X32.5)	螺絲	2
32	P1-32	Washer	墊片	3
33	P1-33	Crank Chamber Cover Oil Shield	防油鐵片	1
34	P1-34	Oil Seal Plug	膠墊	1
35	P1-35	Sewing Head Oil Defense	防油板	1
36	P1-36	Sewing Head Key	機殼固定塊	2
37	P1-37	Screw (9/64-40X8.5)	螺絲	2
38	P1-38	Screw (1/4-28X20)	螺絲	1
39	P1-39	Pin	插銷	1
40	P1-40	Knife Driving Connection Oil Guard	油槽	1

Ref.	Parts			Amt.
No.	No.	Description	品名	Req.
41	P1-41	Knife Driving Connection Felt	油棉墊	1
42	P1-42	Thread Carrier And Hook Driving Rod Oil Guard	防油鐵片	1
43	P1-43	Screw (9/64-40X8)	螺絲	2
44	P1-44	Seal	墊片	2
45	P1-45	Nut	螺母	2
46	P1-46	Sewing Head Cover(Left)	車頭蓋	1
47	P1-47	Emblem	銘牌	1
48	P1-48	Seal Plug	油塞	1
49	P1-49	Seal Plug	油塞	1
50	P1-50	Oil Guide Wire	油線導勾	1
51	P1-51	Crank Chamber Cover, C. Set	曲軸室上蓋組	1
52	P1-52	Top Cover (Middle), C. Set	上蓋(中)組	1
53	P1-53	Top Cover (Front), C. Set	上蓋(前)組	1
54	P1-54	Knife Driving Connection Oil Guard, C. Set	油槽組	1
55	P1-55	Sewing Head Cover Gasket	止油墊片	1
56	P1-56	Sewing Head Cover Gasket(Front)	車頭前蓋	1
57	P1-57	Needle Thrad Take-up Guard	護蓋	1
58	P1-58	Screw(M4-0.7X8)	螺絲	2
59	P1-59	Machine Frame	機殼	1
60	P1-60	Machine Frame	機殼	1
61	P1-61	Sewing Head Cover(Left), C. Set	車頭蓋組	1
62	P1-62	Sewing Head Cover Gasket(Front), C. Set	車頭前蓋組	1

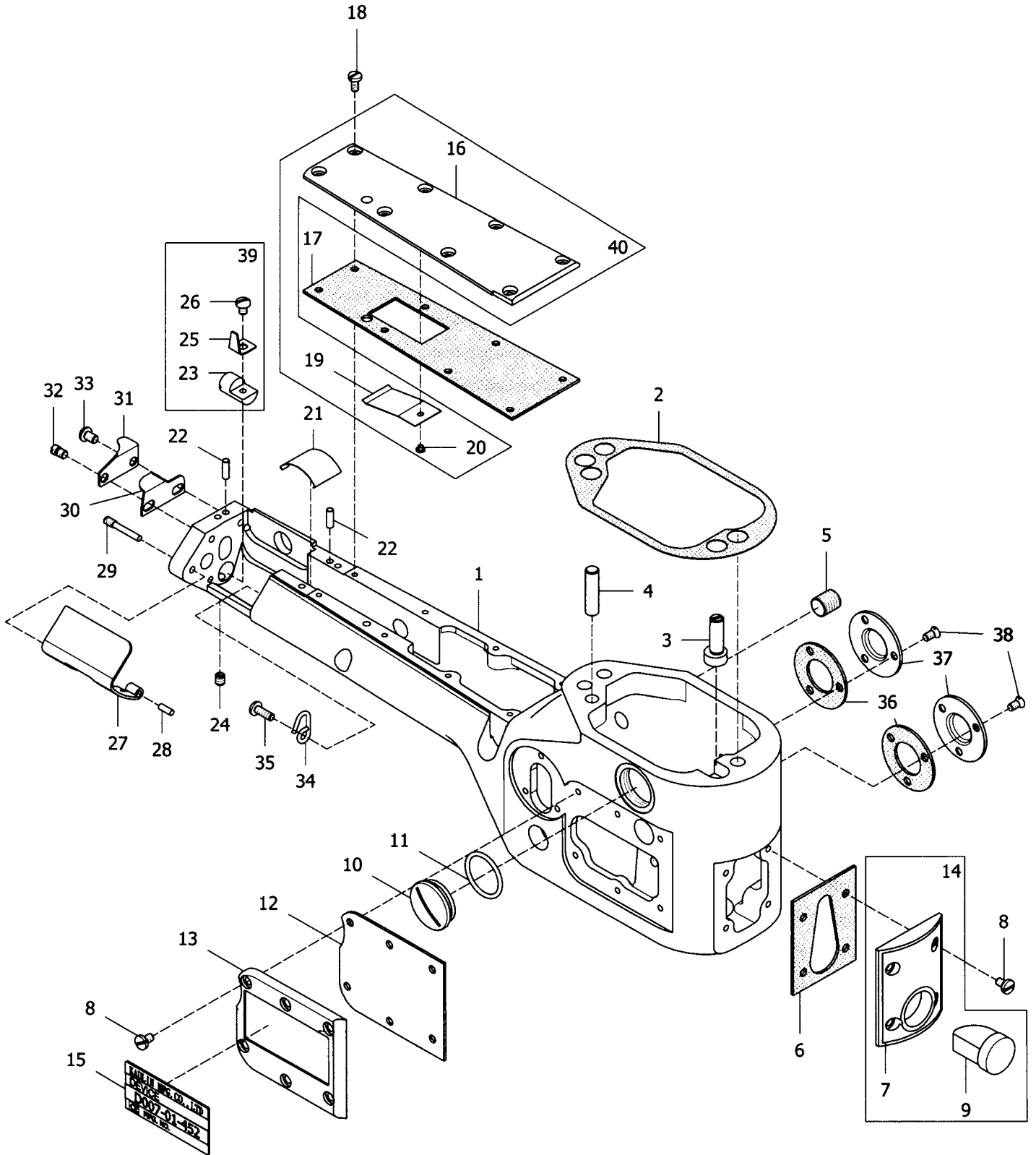

Ref. No.	Parts No.	Description	品 名	Req.
1	P2-1	Sewing Cylinder	圓筒部機殼	1
2	P2-2	Sewing Cylinder Gasket	止油銅墊片	1
3	P2-3	Alignment Pin	調節插銷	1
4	P2-4	Knock Pin	頂出銷	1
5	P2-5	Screw(3/8-24X5.4)	螺絲	1
6	P2-6	Seal Gasket	止油墊片	1
7	P2-7	Cylinder Frame Cover (Front)	前蓋	1
8	P2-8	Screw (9/64-40X8)	螺絲	10
9	P2-9	Oil Gauge	油錶	1
10	P2-10	Screw (M22-1.5X5.7)	螺絲	1
11	P2-11	O-Ring	O型橡膠環	1
12	P2-12	Seal Gasket	止油墊片	1
13	P2-13	Cylinder Frame Cover (Left)	左蓋	1
14	P2-14	Oil Gauge, C.Set	油錶組	1
15	P2-15	Model Plate	型號銘牌	1
16	P2-16	Cylinder Frame Cover (Upper)	上蓋	1
17	P2-17	Seal Gasket	止油墊片	1
18	P2-18	Screw (1/8-44X6.5)	螺絲	8
19	P2-19	Dust Defender (Upper)	防塵蓋(上)	1
20	P2-20	Screw (3/32-56X1.55)	螺絲	1
21	P2-21	Dust Defender (Lower)	防塵蓋(下)	1
22	P2-22	Pin	插銷	2
23	P2-23	Looper Cover Spring Support	彈簧片座	1
24	P2-24	Screw (11/64-40X5)	螺絲	1
25	P2-25	Looper Cover Spring	下勾針蓋彈簧片	1
26	P2-26	Screw (9/64-40X5)	螺絲	1
27	P2-27	Lopper Cover	下勾針蓋	1
28	P2-28	Pin	插銷	1
29	P2-29	Screw (9/64-40X5.7)	螺絲	1
30	P2-30	Chain-off Cutting Knife	割刀固定片	1
31	P2-31	Chain-off Cutting Knife Guard	割刀	1
32	P2-32	Screw (M4-0.7X4.5)	螺絲	1
33	P2-33	Screw (M4-0.7X5.7)	螺絲	1
34	P2-34	Looper Thread Guide Wire	過線圈	1
35	P2-35	Screw (9/64-40X8)	螺絲	1
36	P2-36	Feed Drive Shaft Cover Gasket	止油墊片	2
37	P2-37	Feed Drive Shaft Cover	止油蓋	2
38	P2-38	Screw (9/64-40X7)	螺絲	6
39	P2-39	Looper Cover Spring Support, C. Set	彈簧片座組	1
40	P2-40	Cylinder Frame Cover (Upper), C. Set	上蓋組	1

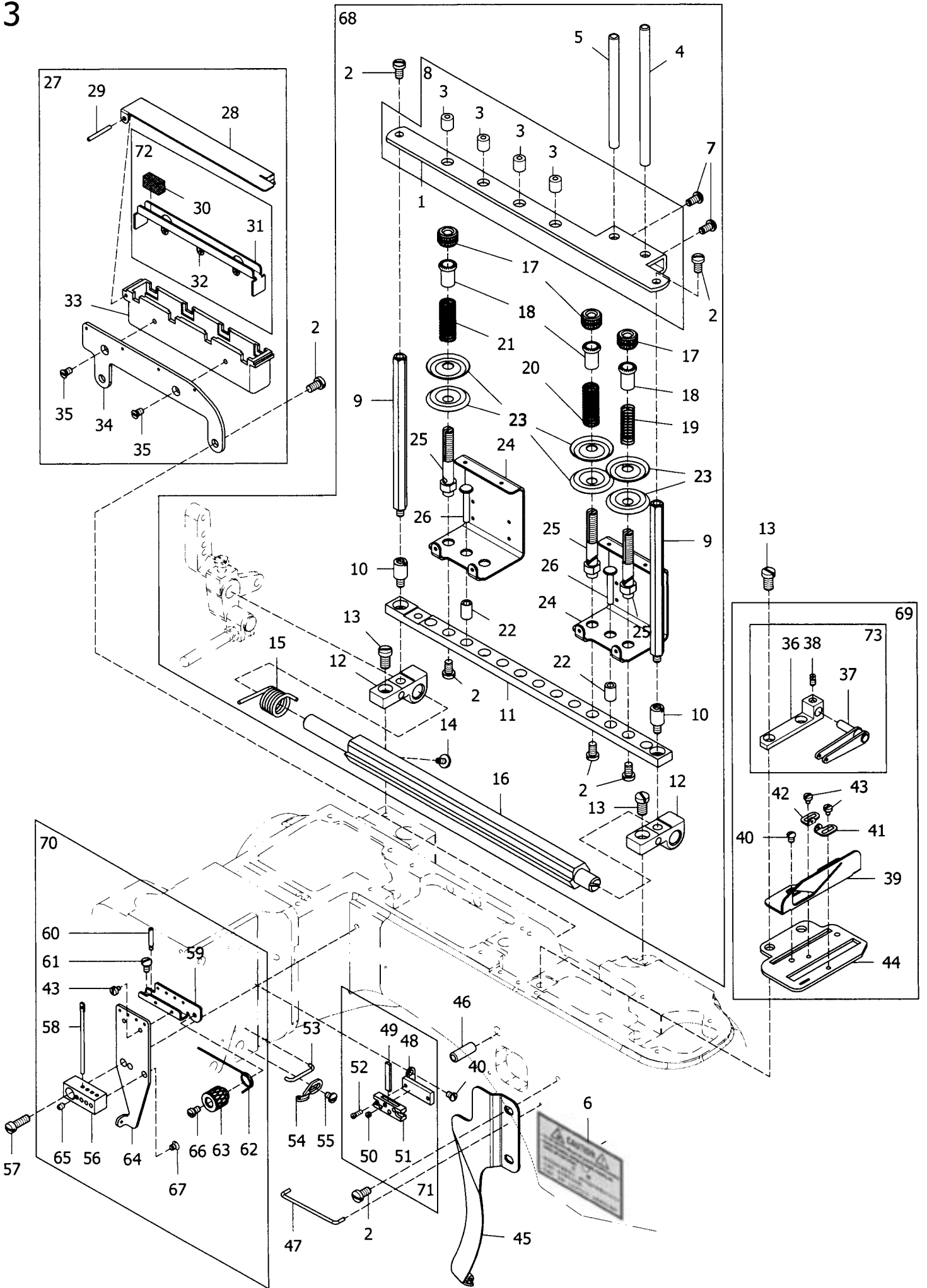

Ref. No.	Parts No.	Description	品名	Req.
1	P3-1	Thread Guide Plate	線架板	1
2	P3-2	Screw (11/64-40X8.3)	螺絲	12
3	P3-3	Thread Eyelet	過線孔	4
4	P3-4	Thread Pipe (Long)	過線管(長)	1
5	P3-5	Thread Pipe (Short)	過線管(短)	1
6	P3-6	Warning Sticker	警告貼紙	1
7	P3-7	Screw (M4-0.7X8)	螺絲	2
8	P3-8	Thread Guide Plate, C. Set	線架板組	1
9	P3-9	Thread Guide Plate Support	線架板支撐棒	2
10	P3-10	Screw (11/64-40X7)	螺絲	2
11	P3-11	Thread Tension Support	上線張力固定座	1
12	P3-12	Thread Tension Support Bracket	上線張力固定座支架	2
13	P3-13	Screw (7/32-32X9.5)	螺絲	4
14	P3-14	Screw (1/8-44X6.4)	螺絲	1
15	P3-15	Tension Release Shaft Spring	張力釋放軸彈簧	1
16	P3-16	Tension Release Shaft	張力釋放軸	1
17	P3-17	Nut	彈簧調整鈕	6
18	P3-18	Tension Spring Bushing	張力彈簧調整固定軸	6
19	P3-19	Looper Thread Tension Spring	下勾針張力彈簧	1
20	P3-20	Top Cover Thread Tension Spring	上飾線張力彈簧	1
21	P3-21	Needle Thread Tension Spring	針線張力彈簧	4
22	P3-22	Tension Release Pin Bushing	張力釋放插銷套管	7
23	P3-23	Thread Tension Disc	張力調整盤	12
24	P3-24	Thread Tension Disc Eyelet	張力調整過線架	3
25	P3-25	Tension Post	張力彈簧支柱	6
26	P3-26	Tension Release Pin	張力釋放插銷	7
27	P3-27	SP Device, C. Set	針線矽油組	1
28	P3-28	Oil Cup Lip	矽油儲存槽蓋	1
29	P3-29	Hinge Pin	鉸鏈插銷	1
30	P3-30	SP Felt	SP矽油氈	4
31	P3-31	SP Felt Stay	SP矽油氈支柱	1
32	P3-32	Oil Wick	油芯	1
33	P3-33	SP Container	矽油儲存槽	1
34	P3-34	SP Container Support	矽油儲存槽固定座	1
35	P3-35	Screw (9/64-40X4.6)	螺絲	2
36	P3-36	Thread Take-up Eyelet Holder	提線桿托架	1
37	P3-37	Thread Take-up Eyelet	提線桿	1
38	P3-38	Screw (1/8-44X6.5)	螺絲	1
39	P3-39	Looper Thread Take-up Guide	下勾針提線桿護架	1
40	P3-40	Screw (1/8-44X4.3)	螺絲	4

Ref.	Parts			
No.	No.	Description	品名	Req.
41	P3-41	Looper Thread Take-up Eyelet(Front)	下勾針提線桿(前)	1
42	P3-42	Looper Thread Take-up Eyelet(Rear)	下勾針提線桿(後)	1
43	P3-43	Screw (3/32-56X3.2)	螺絲	4
44	P3-44	Eyelet Supporting Plate	提線桿固定板	1
45	P3-45	Looper Thread Guard	下勾針線導架	1
46	P3-46	Top Cover Thread Pipe	上飾線過線導管	1
47	P3-47	Looper Thread Guide Wire (Upper)	下勾針線導架金屬線	1
48	P3-48	Needle Thread Strike-off Pin Holder Bracket	過線張力固定架	1
49	P3-49	Needle Thread Strike-off Pin	過線張力調整片	4
50	P3-50	Screw (1/8-44X2)	螺絲	4
51	P3-51	Needle Thread Strike-off Pin Holder	過線張力調整片架	1
52	P3-52	Screw (3/32-56X6.2)	螺絲	2
53	P3-53	Needle Thread Guide Wire	針線導架金屬線	1
54	P3-54	Head Cover Thread Eyelet	上飾線過線片	1
55	P3-55	Screw (1/8-44X4.4)	螺絲	1
56	P3-56	Needle Thread Eyelet Holder	針線張力調整桿座	1
57	P3-57	Screw (11/64-40X13)	螺絲	1
58	P3-58	Needle Thread Eyelet	針線張力調整桿	4
59	P3-59	Stitch Unlocker Mounting Bracket	跳線彈簧架	1
60	P3-60	Screw (11/128-56X3)	螺絲	1
61	P3-61	Screw (1/8-44X5.9)	螺絲	1
62	P3-62	Stitch Unlocking Spring	跳線彈簧	1
63	P3-63	Stitch Unlocking Spring Holder	跳線彈簧調整固定鈕	1
64	P3-64	Needle Bracket	過線支撐架	1
65	P3-65	Screw (1/8-44X3.4)	螺絲	4
66	P3-66	Screw (1/8-44X5.4)	螺絲	1
67	P3-67	Screw (1/8-44X2.7)	螺絲	2
68	P3-68	Thread Guide, C. Set	線架組	1
69	P3-69	Eyelet Supporting Plate, C. Set	提線桿固定板組	1
70	P3-70	Needle Bracket, C. Set	過線支撐架組	1
71	P3-71	Needle Thread Strike-off Pin Holder, C. Set	過線張力調整片架組	1
72	P3-72	SP Felt Stay, C. Set	SP矽油氈支柱組	1
73	P3-73	Thread Take-up Eyelet Holder, C. Set	提線桿托架組	1

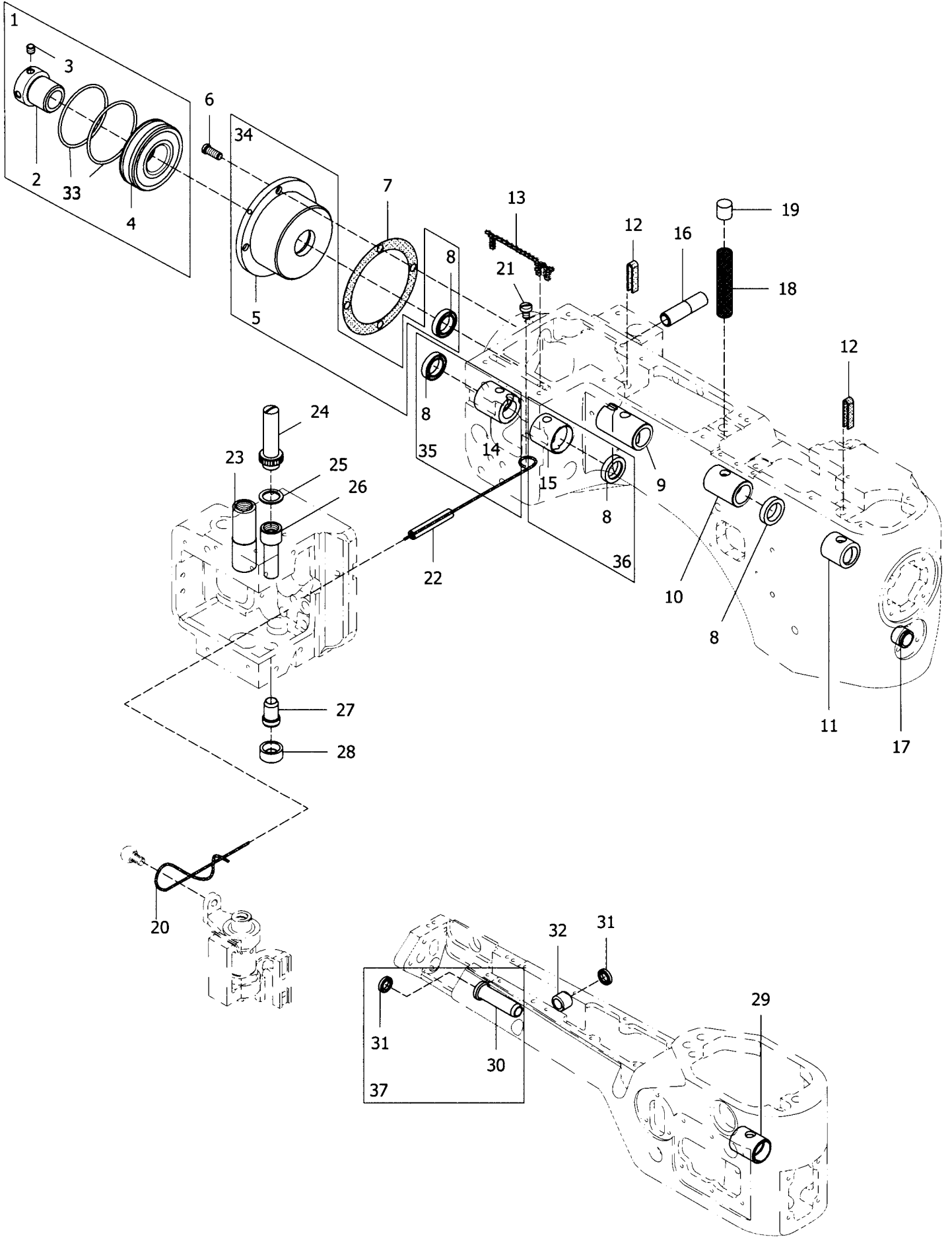

Ref. No.	Parts No.	Description	品 名	Amt. Req.
1	P4-1	Adapter, C. Set	軸承組	1
2	P4-2	Adapter	軸承軸心	1
3	P4-3	Screw (M5-0.8X5)	螺絲	2
4	P4-4	Ball Bearing	軸承	1
5	P4-5	Bearing Housing	軸承固定室	1
6	P4-6	Screw (3/16-32X11.5)	螺絲	4
7	P4-7	Bearing Housing Gasket	軸承固定室墊片	1
8	P4-8	Oil Seal	油封	4
9	P4-9	Crankshing Bushing (Front)	主軸套管(前)	1
10	P4-10	Main Shaft Bushing (Rear)	主軸套管(後)	1
11	P4-11	Main Shaft Bushing (Front)	主軸套管(前)	1
12	P4-12	Oil Wick (Woollen Yarn)	油芯	2
13	P4-13	Oil Wick (Laced Wire)	油芯	1
14	P4-14	Knife Driving Lever Bushing (Rear)	銅套管(後)	1
15	P4-15	Knife Driving Lever Bushing (Front)	銅套管(前)	1
16	P4-16	Presser Foot Lifter Stop Plunger Bushing	襯套	1
17	P4-17	Looper Driving Lever Shaft Bushing	下勾針驅動軸套管	1
18	P4-18	Oil Wick	油芯	1
19	P4-19	Seal Plng	密封塞	1
20	P4-20	Oil Wick	油芯	1
21	P4-21	Screw (11/64-40X8.3)	螺絲	1
22	P4-22	Plastic Pipe	塑膠管	1
23	P4-23	Presser Bar Bushing	壓腳套管	1
24	P4-24	Needle Bar Bushing(Upper)Lid	針柱套管(上)蓋	1
25	P4-25	Gasket	墊片	1
26	P4-26	Needle Bar Bushing(Upper)	針柱套管(上)	1
27	P4-27	Needle Bar Bushing(Lower)	針柱套管(下)	1
28	P4-28	Oil Seal	油封	1
29	P4-29	Looper Rocker Shaft Bushing (Front)	下勾針搖桿軸套管(前)	1
30	P4-30	Looper Rocker Shaft Bushing (Rear)	下勾針搖桿軸套管(後)	1
31	P4-31	Oil Seal	油封	2
32	P4-32	Feed Bar Eccentric Pin Bushing	送料具偏心銷套管	1
33	P4-33	O-Ring	O形橡膠環	2
34	P4-34	Bearing Housing, C. Set	軸承固定室組	1
35	P4-35	Knife Driving Lever Bushing (Rear), C. Set	銅套管(後)組	1
36	P4-36	Knife Driving Lever Bushing (Front), C. Set	銅套管(前)組	1
37	P4-37	Looper Rocker Shaft Bushing (Rear), C. Set	下勾針搖桿軸套管(後)組	1

5

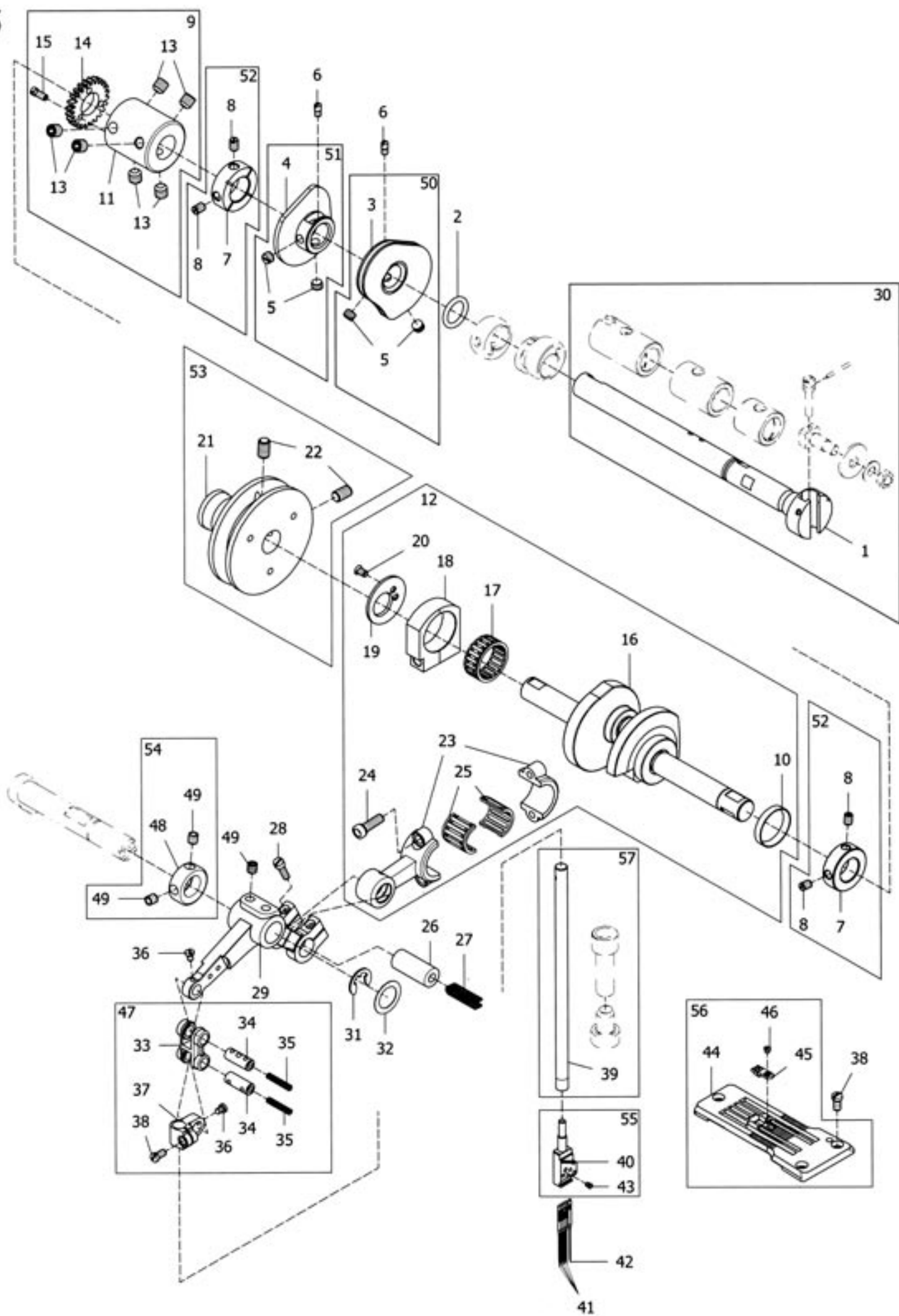

Ref. No.	Parts No.	Description	品名	Amt. Req.
1	P5-1	Main Shaft	主軸	1
2	P5-2	O-ring	O型橡膠環	1
3	P5-3	Looper Thread Take-Up	底線提線凸輪	1
4	P5-4	Top Cover Thread Take-Up	上飾線提線凸輪	1
5	P5-5	Screw (7/32-32X3.6)	螺絲	4
6	P5-6	Positioning Screw (1/8-44X4)	螺絲	2
7	P5-7	Collar	軸環	2
8	P5-8	Screw (11/64-40X6)	螺絲	4
9	P5-9	Main Shaft Coupling, C. Set	主軸連接組	1
10	P5-10	O-ring	O型橡膠環	1
11	P5-11	Main Shaft Coupling	主軸連接套	1
12	P5-12	Thread Carrier and Hook Driving Rod, C. Set	驅動刀組連桿組	1
13	P5-13	Screw (1/4-28X6.3)	螺絲	6
14	P5-14	Pump Driving Gear	泵浦九齒	1
15	P5-15	Screw (1/8-44X6)	螺絲	3
16	P5-16	Crankshaf	曲軸	1
17	P5-17	Needle Bearing	滾針軸承	1
18	P5-18	Thread Carrier and Hook Driving Rod (Right)	驅動刀組連桿軸承套	1
19	P5-19	Needle Bearing Retaining Plate	滾針軸承扣板	1
20	P5-20	Screw (9/64-40X4.8)	螺絲	2
21	P5-21	Pulley	皮帶輪	1
22	P5-22	Screw (1/4-28X10)	螺絲	2
23	P5-23	Needle Bar Lever Connecting Rod	針柱槓桿連桿	1
24	P5-24	Screw (3/16-32X14)	螺絲	2
25	P5-25	Needle Bearing	滾針軸承	1
26	P5-26	Needle Bar Lever Connecting Rod Pin	針柱槓桿連桿插銷	1
27	P5-27	Oil Wick	油芯	1
28	P5-28	Screw (9/64-40X12)	螺絲	2
29	P5-29	Needle Bar Lever	針柱槓桿	1
30	P5-30	Main Shaft, C. Set	主軸組	1
31	P5-31	Retaining Ring	C形扣環	1
32	P5-32	Thrust Ring	墊片	1
33	P5-33	Needle Bar Connecting Link	針柱連桿	1
34	P5-34	Needle Bar Connecting Link Pin	針柱連桿插銷	2
35	P5-35	Oil Wick	吸油繩	2
36	P5-36	Screw (1/8-44X5)	螺絲	2
37	P5-37	Needle Bar Connecting Bracket	針柱連結架	1
38	P5-38	Screw (9/64-40X6.4)	螺絲	4
39	P5-39	Needle Bar	針柱	1
40	P5-40	Needle Clamp	針鑷	1

Ref. No.	Parts No.	Description	品 名	Amt. Req.
41	P5-41	Needle	擊針	4
42	P5-42	Retainer	假針	1
43	P5-43	Screw (3/32-56X2.5)	螺絲	5
44	P5-44	Stitch Plate	針板	1
45	P5-45	Stitch Plate Tongue	針板舌片	1
46	P5-46	Screw (3/32-56X2)	螺絲	1
47	P5-47	Needle Bar Lever, C. Set	針棒組	1
48	P5-48	Collar	軸環	1
49	P5-49	Screw (M5-0.8X5)	螺絲	4
50	P5-50	Looper Thread Take-Up, C. Set	底線提線凸輪組	1
51	P5-51	Top Cover Thread Take-Up, C. Set	上飾線提線凸輪組	1
52	P5-52	Collar, C. Set	軸環組	2
53	P5-53	Pulley, C. Set	皮帶輪組	1
54	P5-54	Collar, C. Set	軸環組	1
55	P5-55	Needle Clamp, C.Set	針鉗組	1
56	P5-56	Stitch Plate, C. Set	針板組	1
57	P5-57	Needle Bar, C. Set	針柱組	1

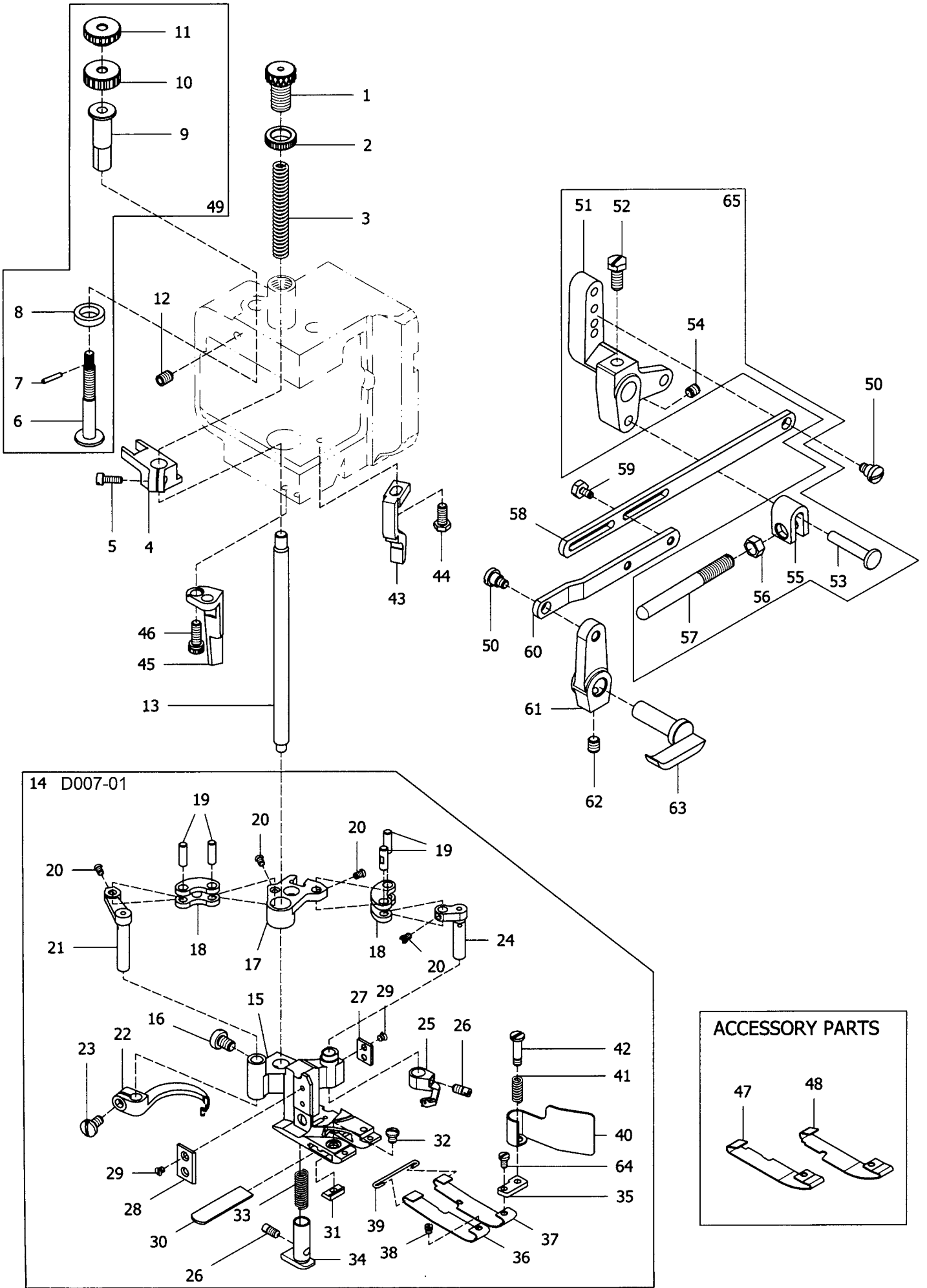

Ref. No.	Parts No.	Description	品名	Amt. Req.
1	P6-1	Adjusting Screw (M12-1X17)	調節螺絲	1
2	P6-2	Lock Nut	保險螺帽	1
3	P6-3	Presser Spring	壓腳彈簧	1
4	P6-4	Presser Bar Connecting Bracket	壓腳推桿連結架	1
5	P6-5	Screw (11/64-40X10.3)	螺絲	1
6	P6-6	Presser Foot Adjusting Screw	壓腳調節彈簧	1
7	P6-7	Pin	插銷	1
8	P6-8	Connecting Bracket Cushion	連結架襯墊	1
9	P6-9	Presser Bar Guide	壓腳導件	1
10	P6-10	Lock Nut	保險螺帽	1
11	P6-11	Adjusting Nut	調節螺帽	1
12	P6-12	Screw (M6-1X8)	螺絲	1
13	P6-13	Presser Bar	壓腳推桿	1
14	P6-14	One Side Cut Presser Foot, C. Set	單切壓腳組	1
15	P6-15	One Side Cut Presser Foot	單切壓腳	1
16	P6-16	Screw (11/64-40X6.3)	螺絲	1
17	P6-17	Carrier/Hook Driving Segment	上勾針驅動扇形片	1
18	P6-18	Carrier/Hook Driving Lever Link	上勾針驅動連桿	2
19	P6-19	Link Pin	連桿插銷	4
20	P6-20	Screw (3/32-56X3.3)	螺絲	4
21	P6-21	Thread Hook Driving Lever	勾針驅動槓桿	1
22	P6-22	Top Cover Thread Hook	上飾線過線勾	1
23	P6-23	Screw (9/64-40X6.8)	螺絲	1
24	P6-24	Top Cover Thread Carrier Driving Lever	上飾線托架驅動槓桿	1
25	P6-25	Top Cover Thread Carrier	上飾線托架	1
26	P6-26	Screw (1/8-44X5)	螺絲	2
27	P6-27	Presser Foot Attach Piece (Right)	壓腳連接片(右)	1
28	P6-28	Presser Foot Attach Piece (Left)	壓腳連接片(左)	1
29	P6-29	Screw(3/32-56X1.5)	螺絲	4
30	P6-30	Lower Knife	下切刀	1
31	P6-31	Lower Knife Clamp	下切刀夾板	1
32	P6-32	Screw (1/8-44X3.5)	螺絲	1
33	P6-33	Yielding Section Spring	小壓具彈簧	1
34	P6-34	Yielding Section	小壓具	1
35	P6-35	Chip Guard Plate	切角防護片座	1
36	P6-36	Presser Foot Spring Plate (Left)	壓腳彈簧片(左)	1
37	P6-37	Presser Foot Spring Plate (Right)	壓腳彈簧片(右)	1
38	P6-38	Screw (3/32-56X2)	螺絲	1
39	P6-39	Spring Plate Holder	彈簧片固定鐵勾	1
40	P6-40	Chip Guard	切角防護片	1

Ref. No.	Parts No.	Description	品名	Amt. Req.
41	P6-41	Chip Guard Spring	切角防護片彈簧	1
42	P6-42	Screw (1/8-44X3.4)	螺絲	1
43	P6-43	Presser Foot Guide (Right)	壓腳導件(右)	1
44	P6-44	Screw (M5-0.8X12)	螺絲	1
45	P6-45	Presser Foot Guide (Left)	壓腳導件(左)	1
46	P6-46	Screw (M5-0.8X14)	螺絲	2
47	P6-47	Presser Foot Spring Plate (B)(Left)	壓腳彈簧片(長)(左)	1
48	P6-48	Presser Foot Spring Plate (B)(Right)	壓腳彈簧片(長)(右)	1
49	P6-49	Presser Bar Guide, C. Set	壓腳導件組	1
50	P6-50	Screw (3/16-32X4)	螺絲	2
51	P6-51	Presser Bar Lifter Lever (Large)	壓腳升降槓桿(大)	1
52	P6-52	Screw (7/32-32X12)	螺絲	1
53	P6-53	Stop Plunger Segment pin	插銷	1
54	P6-54	Screw (M5-0.8X5)	螺絲	1
55	P6-55	Stop Plunger Segment	插銷套	1
56	P6-56	Nut	螺帽	1
57	P6-57	Presser Foot Lifter Stop Plunger	壓具抬起停車柱	1
58	P6-58	Presser Foot Lifter Lever Link (Long)	壓腳升降槓桿連桿(長)	1
59	P6-59	Screw (9/64-40X6.1)	螺絲	2
60	P6-60	Presser Foot Lifter Lever Link (Short)	壓腳升降槓桿連桿(短)	1
61	P6-61	Presser Bar Lifter Lever (Small)	壓腳升降槓桿(小)	1
62	P6-62	Screw (7/32-32X6)	螺絲	1
63	P6-63	Presser Bar Lifter Lever	壓腳拉桿	1
64	P6-64	Screw (3/32-56X4.3)	螺絲	1
65	P6-65	Presser Bar Lifter Lever (Large), C. Set	壓腳升降槓桿(大)組	1

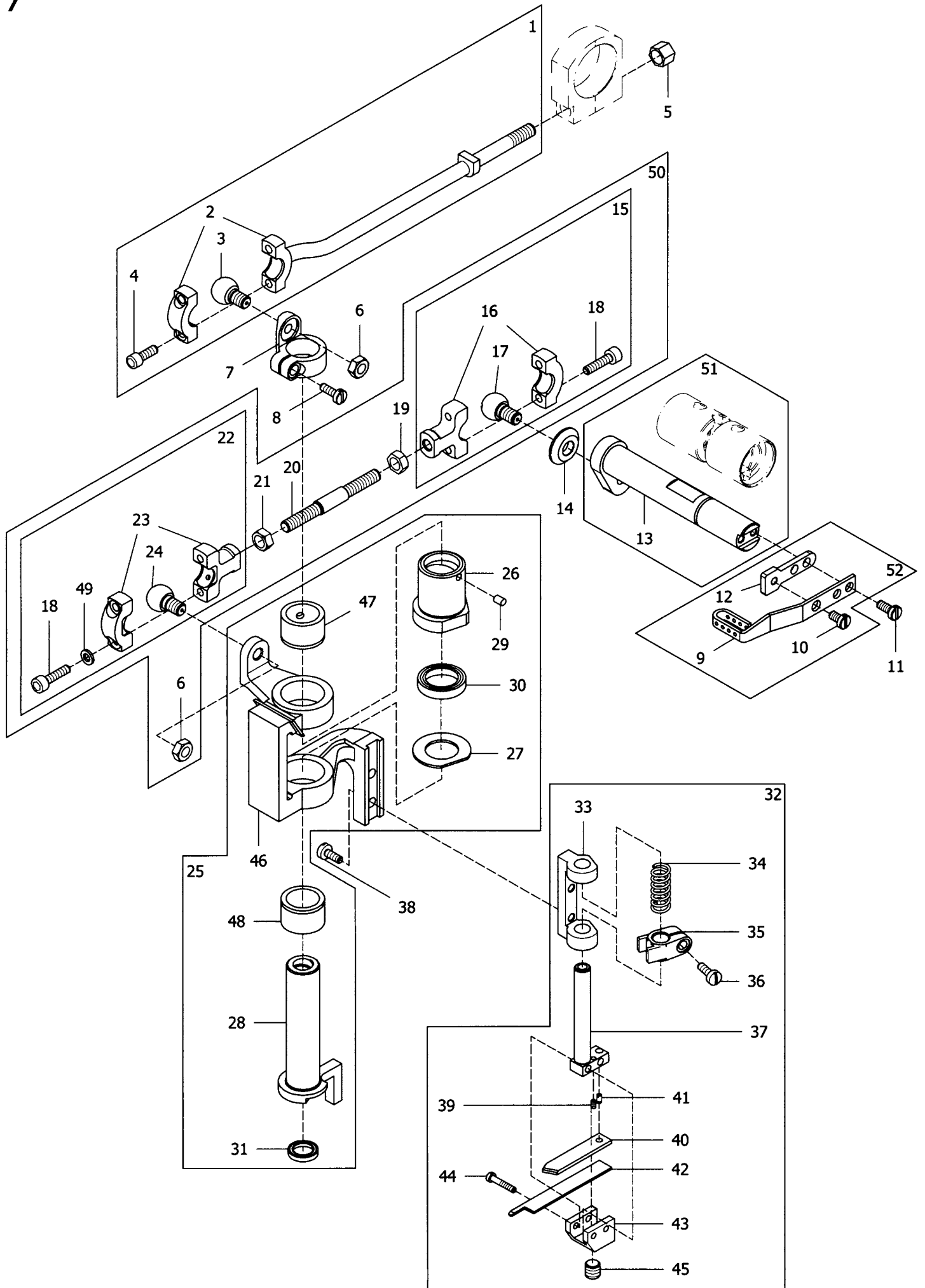

Ref. No.	Parts No.	Description	品名	Amt. Req.
1	P7-1	Carrier/Hook Driving Rod (Left), C. Set	上飾線連桿組	1
2	P7-2	Carrier Hook Driving Rod (Left)	上飾線連桿	1
3	P7-3	Rod Ball (Left)	球頭	1
4	P7-4	Screw (9/64-40X10)	螺絲	2
5	P7-5	Nut	螺帽	1
6	P7-6	Nut	螺帽	2
7	P7-7	Carrier Hook Sleeve Lever	上飾線連桿套筒	1
8	P7-8	Screw(9/64-40X9)	螺絲	1
9	P7-9	Needle Thread Take-up	針線搖臂過線孔	1
10	P7-10	Screw(M3.5-0.6X6)	螺絲	1
11	P7-11	Screw(M3.5-0.6X8)	螺絲	2
12	P7-12	Bracket	固定片	1
13	P7-13	Knife Driving Lever	上切刀傳動槓桿	1
14	P7-14	Steady Washer	穩定墊圈	1
15	P7-15	Knife Driving Connection (Right), C. Set	上切刀傳動連結桿(右)組	1
16	P7-16	Knife Driving Connection(Right)	上切刀驅動連結桿(右)	1
17	P7-17	Knife Driving Connection Ball(Right)	上切刀驅動連結球(右)	1
18	P7-18	Screw (M3.5-0.6X14)	螺絲	4
19	P7-19	Nut (Left-handed Screw)	螺帽(反牙)	1
20	P7-20	Knife Driving Connecting Rod	上切刀驅動連結桿	1
21	P7-21	Nut	螺帽	1
22	P7-22	Knife Driving Connection (Left), C. Set	上切刀傳動連結桿(左)組	1
23	P7-23	Knife Driving Connection (Left)	上切刀驅動連結桿(左)	1
24	P7-24	Rod Ball (Left)	球頭	1
25	P7-25	Knife Holder Bracket, C. Set	上切刀固定座托架組	1
26	P7-26	Thread Carrier and Hook Sleeve Bushing	切刀固定座托架襯套	1
27	P7-27	Bushing Ring	襯套墊片	1
28	P7-28	Carrier/Hook Driving Sleeve	上飾線連桿柱	1
29	P7-29	Oil Wick	油芯	1
30	P7-30	Oil Seal	油封	1
31	P7-31	Oil Seal	油封	1
32	P7-32	Knife Holder Guide Collar, C. Set	活動刀組	1
33	P7-33	Knife Holder Shank Support	上切刀固定座支架	1
34	P7-34	Knife Holder Spring	上切刀固定座彈簧	1
35	P7-35	Knife Holder Guide Collar	上切刀彈簧固定座	1
36	P7-36	Screw (9/64-40X9)	螺絲	1
37	P7-37	Knife Holder Shank	上切刀固定座柄	1
38	P7-38	Screw (9/64-40X8)	螺絲	2
39	P7-39	Screw (3/32-56X3.5)	螺絲	1
40	P7-40	Knife Support	上切刀支架	1

Ref. No.	Parts No.	Description	品 名	Amt. Req.
41	P7-41	Screw (3/32-56X1.2)	螺絲	1
42	P7-42	Upper Knife	上切刀	1
43	P7-43	Knife Holder	上切刀固定座	1
44	P7-44	Screw (3/32-56X7)	螺絲	2
45	P7-45	Screw (1/4-40X6)	螺絲	1
46	P7-46	Knife Holder Bracket	上切刀固定座托架	1
47	P7-47	Sleeve Bushing (Upper)	襯套(上)	1
48	P7-48	Sleeve Bushing (Lower)	襯套(下)	1
49	P7-49	Washer	墊片	2
50	P7-50	Knife Driving Connection, C. Set	上切刀傳動連結桿組	1
51	P7-51	Knife Driving Lever, C. Set	上切刀傳動槓桿組	1
52	P7-52	Needle Thread Take-up, C. Set	針線搖臂過線孔組	1

8

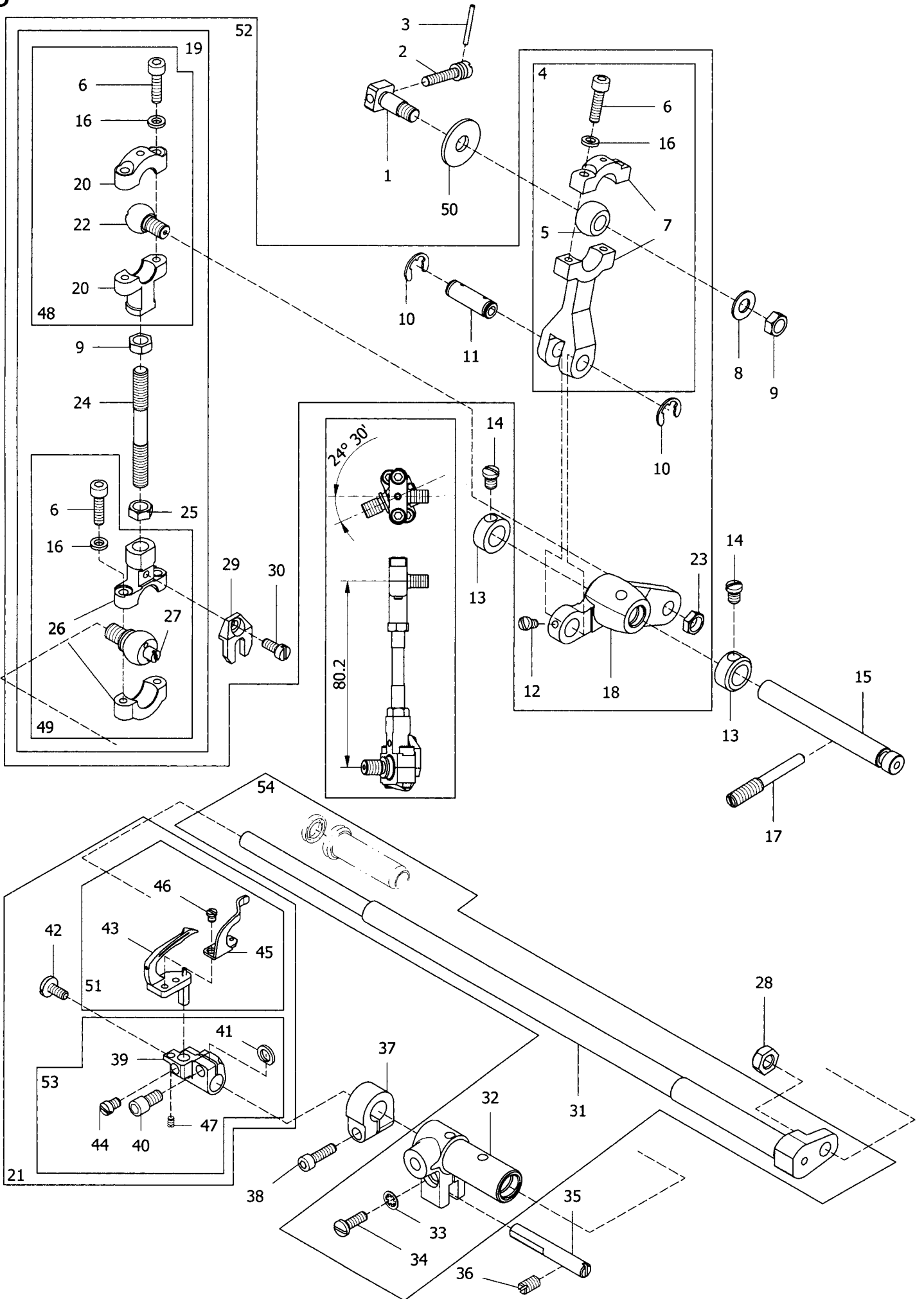

Ref. No.	Parts No.	Description	品名	Amt. Req.
1	P8-1	Looper Driving Crank Pin	下勾針驅動曲柄插銷	1
2	P8-2	Screw (9/64-40X16.3)	螺絲	1
3	P8-3	Roll Pin for Main Shaft	插銷	1
4	P8-4	Looper Lever Driving Rod, C. Set	下勾針驅動桿組	1
5	P8-5	Looper Lever Driving Rod Ball	下勾針驅動桿球	1
6	P8-6	Screw (M3.5-0.6X14)	螺絲	6
7	P8-7	Looper Lever Driving Rod	下勾針驅動桿	1
8	P8-8	Washer	墊片	1
9	P8-9	Nut (Left-handed Screw)	螺帽(反牙)	2
10	P8-10	Retaining Ring	扣環	2
11	P8-11	Looper Lever Driving Rod Pin	下勾針驅動桿插銷	1
12	P8-12	Screw (1/8-44X5)	螺絲	1
13	P8-13	Collar	軸環	2
14	P8-14	Screw (11/64-40X5.5)	螺絲	2
15	P8-15	Looper Lever Shaft	下勾針槓桿軸	1
16	P8-16	Washer	墊片	6
17	P8-17	Screw (7/32-32X20)	螺絲	1
18	P8-18	Looper Lever	下勾針槓桿	1
19	P8-19	Looper Driving Connection Rod, C. Set	下勾針驅動連桿組	1
20	P8-20	Looper Driving Connection(Upper)	下勾針驅動連桿(上)	1
21	P8-21	Looper, C. Set	勾針組	1
22	P8-22	Looper Driving Connection Ball(Upper)	下勾針驅動連桿球(上)	1
23	P8-23	Nut	螺帽	1
24	P8-24	Looper Driving Connecting Rod	下勾針驅動連結桿	1
25	P8-25	Nut	螺帽	1
26	P8-26	Looper Driving Connection(Lower)	下勾針驅動連桿(下)	1
27	P8-27	Looper Driving Connection Ball(Lower)	下勾針驅動連桿球(下)	1
28	P8-28	Nut	螺帽	1
29	P8-29	Steady Fork	穩定叉	1
30	P8-30	Screw (M3.5-0.6X8)	螺絲	1
31	P8-31	Looper Rocker Shaft	下勾針搖桿軸	1
32	P8-32	Looper Rocker Shaft Sleeve	下勾針搖桿軸套筒	1
33	P8-33	Washer	墊片	1
34	P8-34	Screw (9/64-40X10.9)	螺絲	1
35	P8-35	Looper Rocker Shaft Sleeve Guide	下勾針搖桿軸套筒導件	1
36	P8-36	Screw (3/16-32X8)	螺絲	1
37	P8-37	Collar	下勾針搖桿軸環	1
38	P8-38	Screw(11/64-40X13)	螺絲	1
39	P8-39	Looper Holder	下勾針固定座	1
40	P8-40	Screw (11/64-40X8.3)	螺絲	1

Ref. No.	Parts No.	Description	品名	Amt. Req.
41	P8-41	Packing	襯墊	1
42	P8-42	Adjusting Screw(9/64-40X8.2)	調節螺絲	1
43	P8-43	Looper	勾針	1
44	P8-44	Screw (9/64-40X4.9)	螺絲	1
45	P8-45	Needle Guard(Front)	防護片(前)	1
46	P8-46	Screw (29/256-48X3.2)	螺絲	2
47	P8-47	Screw (3/32-56X3.5)	螺絲	1
48	P8-48	Looper Driving Connection(Upper), C. Set	下勾針驅動連結組(上)	1
49	P8-49	Looper Driving Connection(Lower), C. Set	下勾針驅動連結組(下)	1
50	P8-50	Spacer	墊片	1
51	P8-51	Looper, C. Set	勾針組	1
52	P8-52	Looper Lever, C. Set	下勾針槓桿組	1
53	P8-53	Looper Holder, C. Set	下勾針固定座組	1
54	P8-54	Looper Rocker Shaft, C. Set	下勾針搖桿軸組	1

9

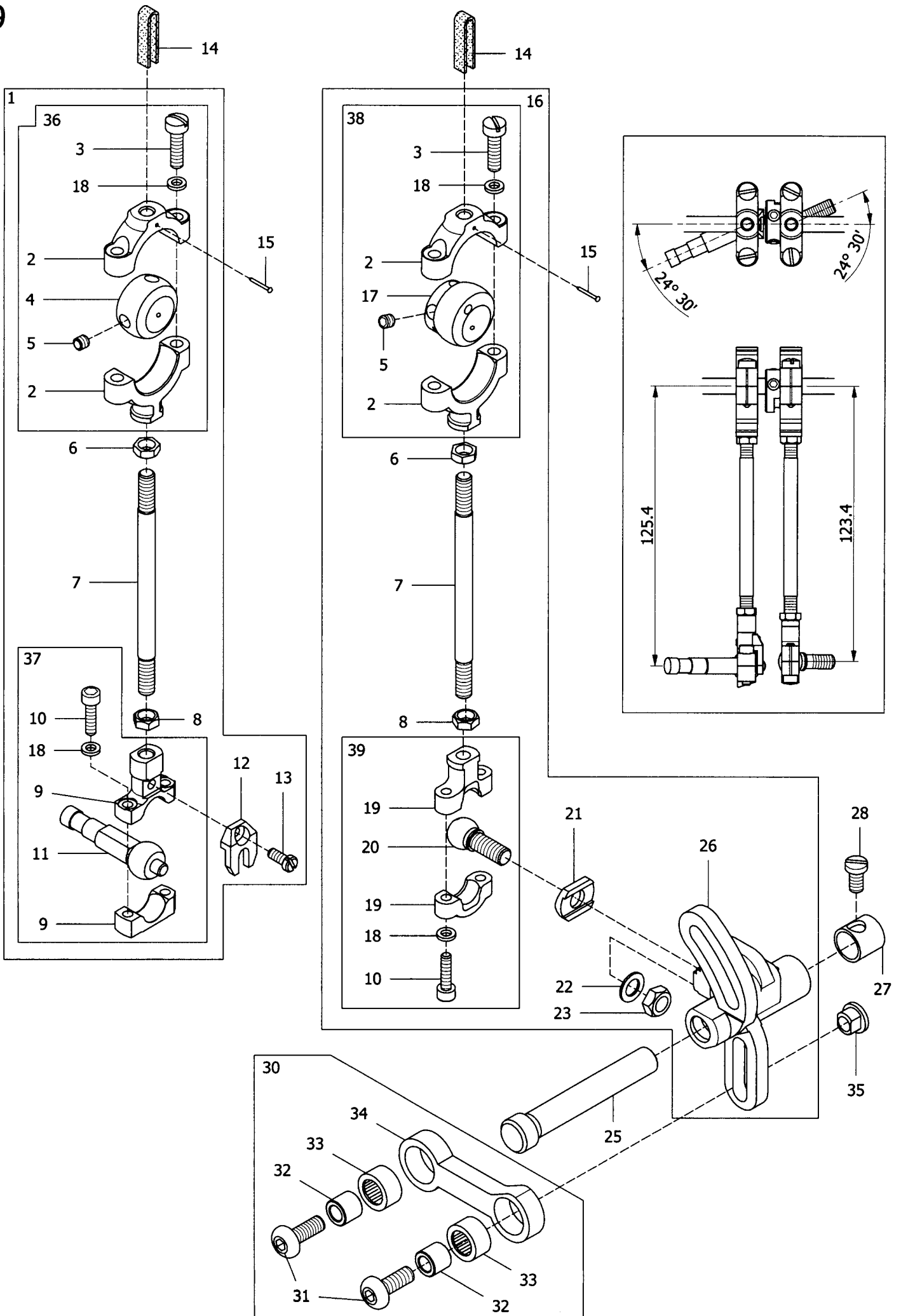

Ref. No.	Parts No.	Description	品 名	Amt. Req.
1	P9-1	Feed Lift Eccentric, C. Set	送料具提升偏心輪組	1
2	P9-2	Feed Lift Connection (Upper)	送料具提升連桿(上)	2
3	P9-3	Screw (11/64-40X16)	螺絲	4
4	P9-4	Feed Lift Eccentric Ball	送料具提升偏心輪球	1
5	P9-5	Screw (11/64-40X4)	螺絲	4
6	P9-6	Nut (Left-handed Screw)	螺帽	2
7	P9-7	Feed Lift Eccentric Connecting Rod	送料具提升偏心輪連桿	2
8	P9-8	Nut	螺帽	2
9	P9-9	Feed Lift Connection (Lower)	送料具提升連桿(下)	1
10	P9-10	Screw (M3.5-0.6X14)	螺絲	4
11	P9-11	Feed Lift Connection Ball	送料具提升連桿球	1
12	P9-12	Steady Fork	穩定叉	1
13	P9-13	Screw (M3.5-0.6X8)	螺絲	1
14	P9-14	Oil Wick	油芯	2
15	P9-15	Pin	大頭針	2
16	P9-16	Feed Drive Eccentric, C. Set	送料具驅動偏心輪組	1
17	P9-17	Feed Drive Eccentric Ball	送料具驅動偏心輪球	1
18	P9-18	Washer	墊片	8
19	P9-19	Feed Drive Connection(Lower)	送料具驅動連桿(下)	1
20	P9-20	Feed Drive Connection Ball	送料具驅動連桿球	1
21	P9-21	Steady Washer	穩定墊片	1
22	P9-22	Washer	墊片	1
23	P9-23	Nut	螺帽	1
24	P9-25	Feed Drive Shaft	送料具驅動軸	1
25	P9-26	Feed Drive/Looper Avoid Lever	送料具槓桿	1
26	P9-27	Feed Drive Shaft Bushing	送料具驅動軸套筒	1
27	P9-28	Screw (3/16-32X9.1)	螺絲	1
28	P9-30	Looper Avoid Connecting Rod, C. Set	勾針運動連桿組	1
29	P9-31	Screw (7/32-32X10)	螺絲	2
30	P9-32	Looper Avoid Connecting Rod Bushing	連桿軸承襯套	2
31	P9-33	Needle Bearing	軸承	2
32	P9-34	Looper Avoid Connecting Rod	勾針運動連桿	1
33	P9-35	Looper Avoid Adjusting Nut	調整螺帽	1
34	P9-36	Feed Lift Connection(Upper), C. Set	送料具提升連桿(上)組	1
35	P9-37	Feed Lift Connection(Lower), C. Set	送料具提升連桿(下)組	1
36	P9-38	Feed Drive Eccentric(Upper), C. Set	送料具提升偏心輪(上)組	1
37	P9-39	Feed Drive Eccentric(Lower), C. Set	送料具提升偏心輪(下)組	1

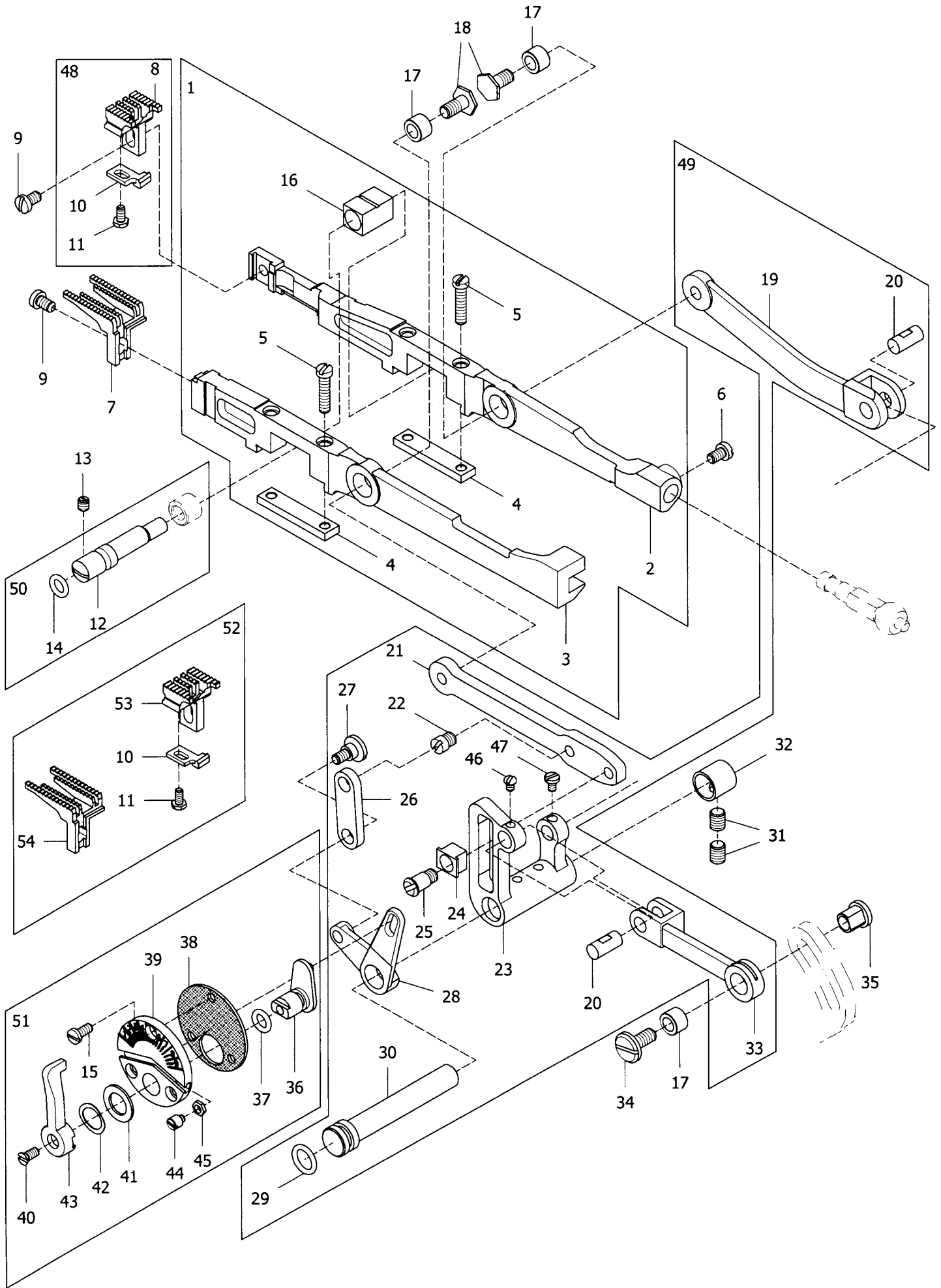

Ref. No.	Parts No.	Description	品 名	Amt. Req.
1	P10-1	Feed Bar, C. Set	送料具固定座組	1
2	P10-2	Main Feed Bar	主送料具固定座	1
3	P10-3	Differential Feed Bar	差動送料具固定座	1
4	P10-4	Feed Bar Plate	送料具固定座片	2
5	P10-5	Screw (11/64-40X18.5)	螺絲	4
6	P10-6	Screw (11/64-40X7)	螺絲	1
7	P10-7	Differential Feed Dog	差動齒	1
8	P10-8	Main Feed Dog	主齒	1
9	P10-9	Screw (11/64-40X7.8)	螺絲	2
10	P10-10	Needle Guard(Rear)	頂針片(後)	1
11	P10-11	Screw (1/8-44X4.8)	螺絲	1
12	P10-12	Feed Bar Eccentric Pin	送料具偏心銷	1
13	P10-13	Screw (11/64-40X5)	螺絲	1
14	P10-14	O-ring	O型橡膠環	1
15	P10-15	Screw (9/64-40X6.4)	螺絲	3
16	P10-16	Feed Bar Slide Block	送料具滑塊	1
17	P10-17	Feed Rocker Link Bushing	送料具搖桿套筒	3
18	P10-18	Screw (7/32-32X6.5)	螺絲	2
19	P10-19	Main Feed Bar Driving Link	主送料具固定座驅動桿	1
20	P10-20	Feed Rocker Link Pin	送料具搖桿插銷	2
21	P10-21	Differential Feed Bar Driving Link	差動送料具驅動桿	1
22	P10-22	Screw (7/32-32X5)	螺絲	1
23	P10-23	Feed Rocker	送料具搖桿	1
24	P10-24	Differential Feed Bar Driving Link Slider	差動送料具調整滑塊	1
25	P10-25	Screw (7/32-32X4.6)	螺絲	1
26	P10-26	Differential Feed Adjusting Link	差動送料具調節桿	1
27	P10-27	Screw (11/64-40X6.6)	螺絲	1
28	P10-28	Differential Feed Adjusting Lever	差動送料具調節槓桿	1
29	P10-29	O-ring	O型橡膠環	1
30	P10-30	Feed Rocker Shaft	送料具搖桿軸	1
31	P10-31	Screw (M6-1X8)	螺絲	2
32	P10-32	Feed Rocker Shaft Bushing	送料具搖桿軸套筒	1
33	P10-33	Feed Rocker Link	送料具搖桿連桿	1
34	P10-34	Screw (7/32-32X10.5)	螺絲	1
35	P10-35	Feed Adjusting Nut	送料具調節螺帽	1
36	P10-36	Differential Feed Adjusting Lever (Middle)	差動送料具調節槓桿(中)	1
37	P10-37	O-ring	O型橡膠環	1
38	P10-38	Differential Feed Adjusting Dial Gasket	差動調節標度盤墊片	1
39	P10-39	Differential Feed Adjusting Dial	差動送料具調節標度盤	1
40	P10-40	Screw (9/64-40X8.5)	螺絲	1

Ref.	Parts			Amt.
No.	No.	Description	品名	Req.
41	P10-41	Spacer (Fiber)	墊片(纖維)	1
42	P10-42	Corrugated Washer	波狀墊片	1
43	P10-43	Differential Feed Operating Lever	差動送料具操作桿	1
44	P10-44	Screw (M3-0.5X2.6)	螺絲	2
45	P10-45	Nut	螺帽	2
46	P10-46	Screw (1/8-44X3.9)	螺絲	1
47	P10-47	Screw (1/8-44X4.7)	螺絲	1
48	P10-48	Main Feed Dog, C. Set	主齒組	1
49	P10-49	Feed Rocker, C. Set	送料具搖桿組	1
50	P10-50	Feed Bar Eccentric Pin, C. Set	送料具偏心銷組	1
51	P10-51	Differential Feed Adjusting Dial, C. Set	差動調節標度盤組	1
52	P10-52	Feed Rocker, C. Set (Thick material)	送料具搖桿組(厚料用)	1
53	P10-53	Main Feed Dog	主齒	1
54	P10-54	Differential Feed Dog	差動齒	1

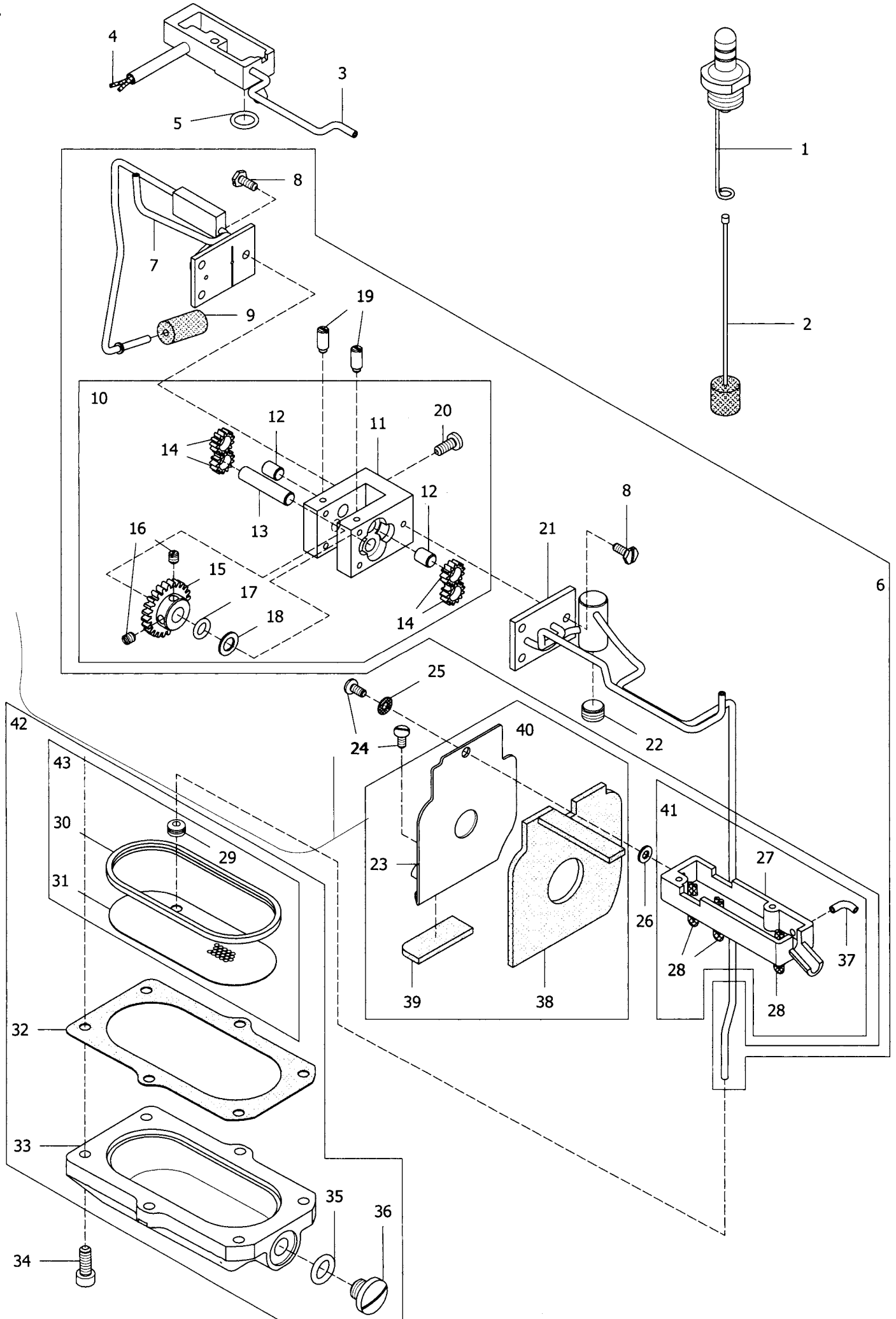

Ref. No.	Parts No.	Description	品 名	Amt. Req.
1	P11-1	Crank Chamber Oil Gauge Unit	油錶	1
2	P11-2	Oil Height Indicator	油量指示棒	1
3	P11-3	Oil Receiver (Rear)	油量接收器(後)	1
4	P11-4	Oil Wick	油芯	1
5	P11-5	O-ring	O型橡膠環	1
6	P11-6	Pump, C. Set	油泵組	1
7	P11-7	Pump Housing Cover (Rear) Unit	吸油管組(後)	1
8	P11-8	Screw (9/64-40X9.7)	螺絲	6
9	P11-9	In-take Filter	吸油氈	1
10	P11-10	Pump, C. Set	油泵組	1
11	P11-11	Pump Housing	油泵室	1
12	P11-12	Pump Gear Shaft (Short)	油泵齒輪(短)	2
13	P11-13	Pump Gear Shaft (Long)	油泵齒輪(長)	1
14	P11-14	Oil Pump Gear	油泵齒輪	4
15	P11-15	Pump Driven Gear	油泵驅動齒輪	1
16	P11-16	Screw (11/64-40X5)	螺絲	2
17	P11-17	O-ring	O型橡膠環	1
18	P11-18	Washer	墊片	1
19	P11-19	Screw (9/64-40X3)	螺絲	2
20	P11-20	Screw (11/64-40X10.5)	螺絲	2
21	P11-21	Pump Housing Cover (Front) Unit	吸油管組(前)	1
22	P11-22	Screw (M10-1.5X6.1)	螺絲	1
23	P11-23	Thread Take-up Oil Defender Unit	防油板	1
24	P11-24	Screw (9/64-40X7)	螺絲	2
25	P11-25	Seal	防油墊片	1
26	P11-26	Washer	墊片	1
27	P11-27	Oil Receiver (Front)	油量接收器(前)	1
28	P11-28	Oil Wick	油芯	3
29	P11-29	Rubber Bushing	橡膠套筒	1
30	P11-30	Oil Filter Screen Rubber Seal	過濾油網橡膠油封	1
31	P11-31	Oil Filter Screen	過濾油網	1
32	P11-32	Oil Reservoir Gasket	油槽防油墊	1
33	P11-33	Oil Reservoir	油槽	1
34	P11-34	Screw (M5-0.8X14)	螺絲	6
35	P11-35	O-ring	O型橡膠環	1
36	P11-36	Drain Hole Screw (3/8-24X8)	螺絲	1
37	P11-37	Oil Tube	銅管	1
38	P11-38	Thread Take-up Oil Defender Unit	防油板氈	1
39	P11-39	Thread Take-up Oil Defender Unit	防油板氈	1
40	P11-40	Thread Take-up Oil Defender Unit, C. Set	防油板組	1
41	P11-41	Oil Receiver (Front), C. Set	油量接收器(前)組	1
42	P11-42	Oil Reservoir, C. Set	油槽組	1
43	P11-43	Oil Filter Screen, C. Set	過濾油網組	1

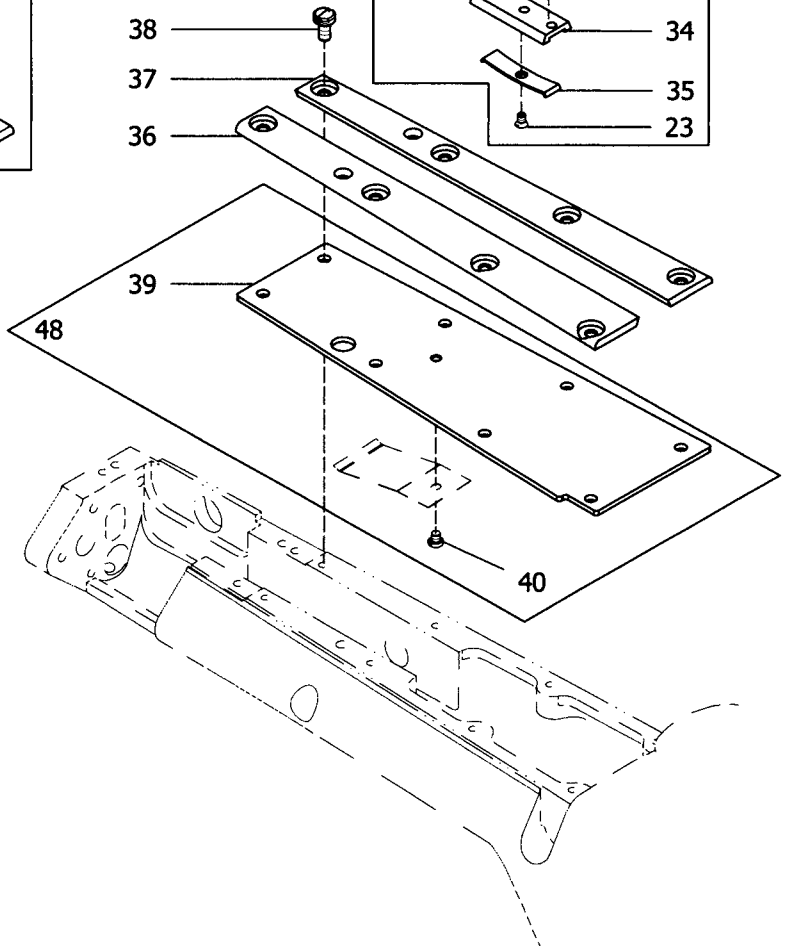
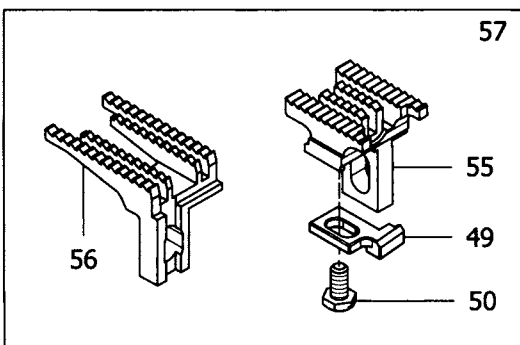
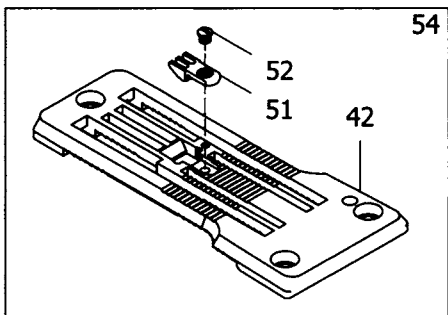
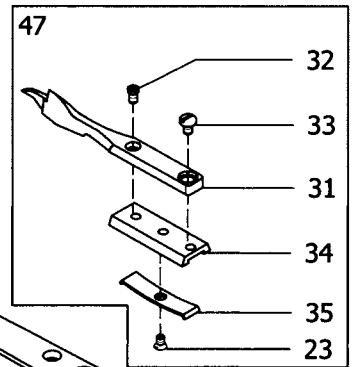
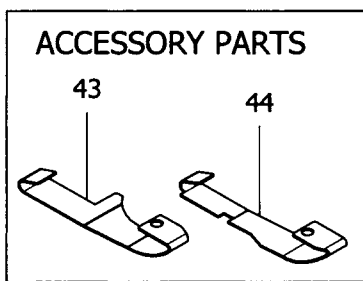
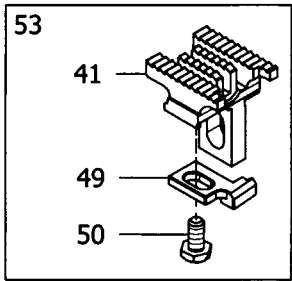
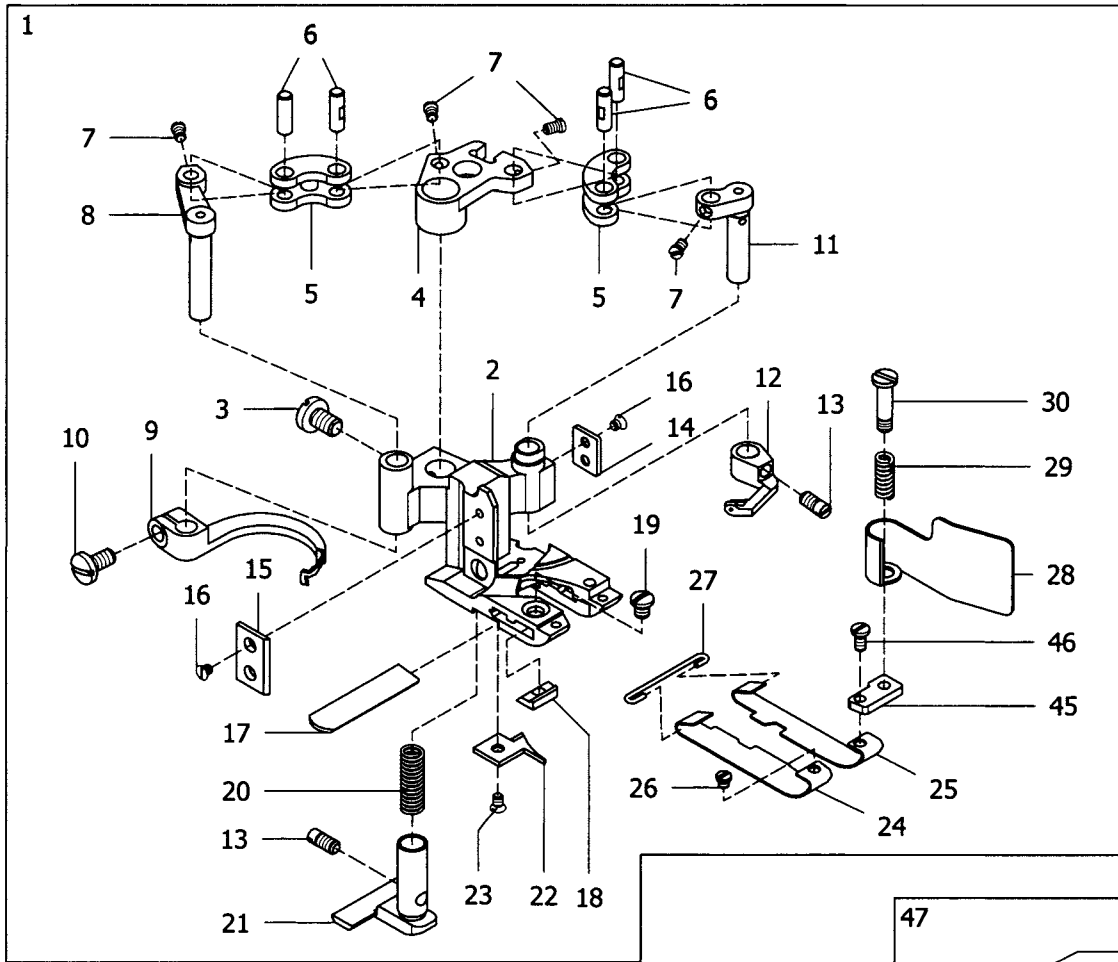

Ref. No.	Parts No.	Description	品名	Amt. Req.
1	P12-1	Double Side Cut Presser Foot, C. Set	雙切壓腳組	1
2	P12-2	Double Side Cut Presser Foot	雙切壓腳	1
3	P12-3	Screw (11/64-40X6.3)	螺絲	1
4	P12-4	Carrier/Hook Driving Segment	上勾針驅動扇形片	1
5	P12-5	Carrier/Hook Driving Lever Link	上勾針驅動連桿	2
6	P12-6	Link Pin	連桿插銷	4
7	P12-7	Screw (3/32-56X3.3)	螺絲	4
8	P12-8	Thread Hook Driving Lever	勾針驅動槓桿	1
9	P12-9	Top Cover Thread Hook	上飾線過線勾	1
10	P12-10	Screw (9/64-40X6.8)	螺絲	1
11	P12-11	Top Cover Thread Carrier Driving Lever	上飾線托架驅動槓桿	1
12	P12-12	Top Cover Thread Carrier	上飾線過線勾右	1
13	P12-13	Screw (1/8-44X5)	螺絲	2
14	P12-14	Presser Foot Attach Piece (Right)	壓腳連接片(右)	1
15	P12-15	Presser Foot Attach Piece (Left)	壓腳連接片(左)	1
16	P12-16	Screw(3/32-56X1.5)	螺絲	4
17	P12-17	Lower Knife	下切刀	1
18	P12-18	Lower Knife Clamp	下切刀夾板	1
19	P12-19	Screw (1/8-44X3.5)	螺絲	1
20	P12-20	Yielding Section Spring	小壓具彈簧	1
21	P12-21	Yielding Section	小壓具	1
22	P12-22	Presser Foot Tongue	壓腳舌片	1
23	P12-23	Screw(3/32-56X2.5)	螺絲	2
24	P12-24	Presser Foot Spring Plate (Left)	壓腳彈簧片(左)	1
25	P12-25	Presser Foot Spring Plate (Right)	壓腳彈簧片(右)	1
26	P12-26	Screw (3/32-56X2)	螺絲	1
27	P12-27	Spring Plate Holder	彈簧片固定座	1
28	P12-28	Chip Guard	切角防護片	1
29	P12-29	Chip Guard Spring	切角防護片彈簧	1
30	P12-30	Screw (1/8-44X3.4)	螺絲	1
31	P12-31	Lap Former	前導布器	1
32	P12-32	Screw (3/32-56X3.5)	螺絲	1
33	P12-33	Screw (3/32-56X3.9)	螺絲	1
34	P12-34	Lap Former Slide Block	前導布器滑塊	1
35	P12-35	Lap Former Slide Block Spring	前導布器滑塊彈簧片	1
36	P12-36	Lap Former Guide Plate (Left)	前導布器導軌(左)	1
37	P12-37	Lap Former Guide Plate (Right)	前導布器導軌(右)	1
38	P12-38	Screw (1/8-44X8)	螺絲	8
39	P12-39	Sewing Cylinder Cover (Upper)	下巴蓋板	1
40	P12-40	Screw (3/32-56X2.1)	螺絲	1

Ref.	Parts			Amt.
No.	No.	Description	品 名	Req.
41	P12-41	Main Feed Dog	主齒	1
42	P12-42	Stitch Plate	針板	1
43	P12-43	Presser Foot Spring Plate (B)(Left)	壓腳彈簧片(長)(左)	1
44	P12-44	Presser Foot Spring Plate (B)(Right)	壓腳彈簧片(長)(右)	1
45	P12-45	Chip Guard Plate	切角防護片座	1
46	P12-46	Screw (3/32-56X4.3)	螺絲	1
47	P12-47	Lap Former, C. Set	前導布器組	1
48	P12-48	Sewing Cylinder Cover (Upper), C. Set	下巴蓋板組	1
49	P12-49	Needle Guard(Rear)	頂針片(後)	1
50	P12-50	Screw (1/8-44X4.8)	螺絲	1
51	P12-51	Stitch Plate Tongue	針板舌片	1
52	P12-52	Screw (3/32-56X2)	螺絲	1
53	P12-53	Main Feed Dog, C. Set	主齒組	1
54	P12-54	Stitch Plate, C. Set	針板組	1
55	P12-55	Main Feed Dog	主齒	1
56	P12-56	Differential Feed Dog	差動齒	1
57	P12-57	Feed Rocker, C. Set (Thick material)	送料具搖桿組(厚料用)	1

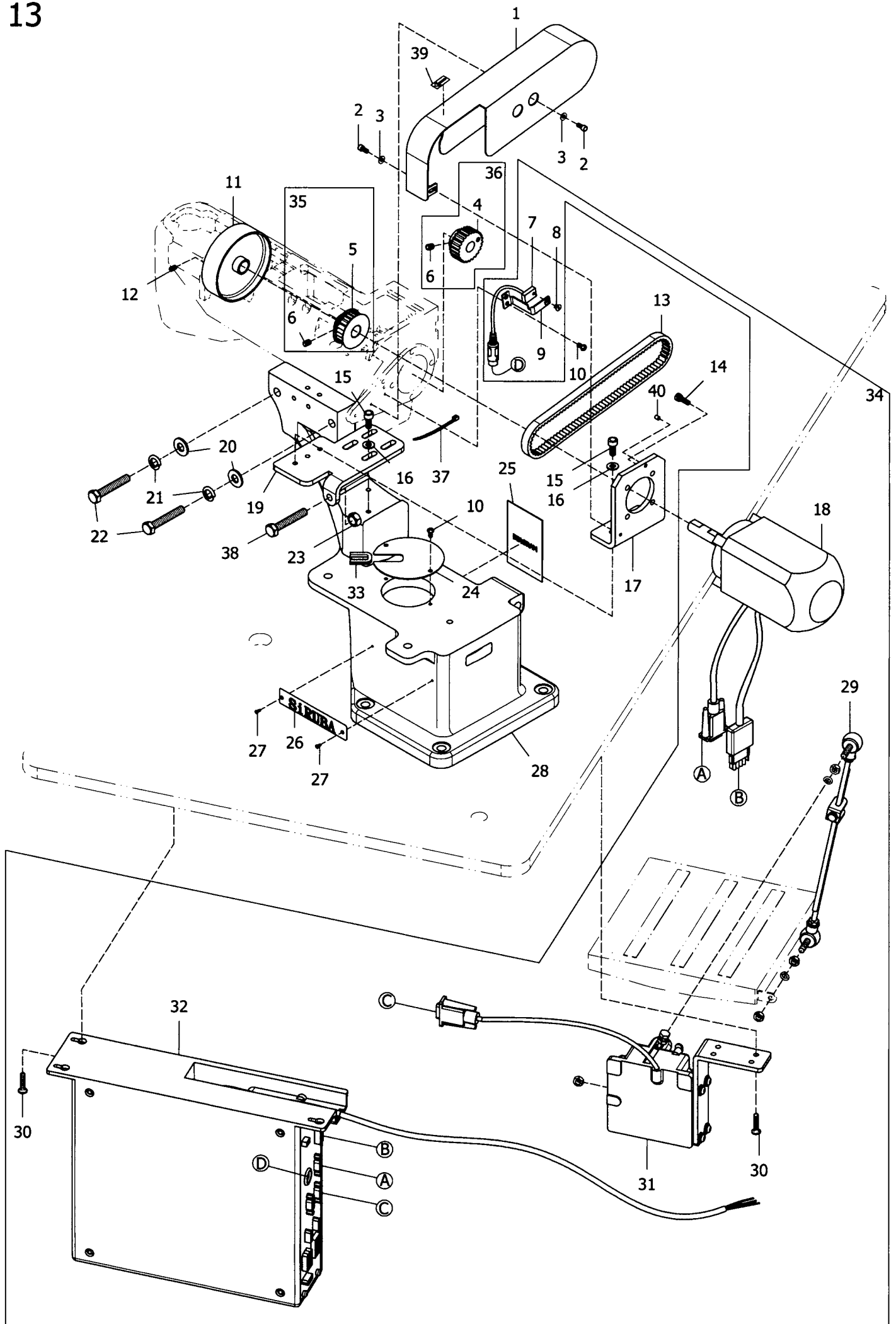

Ref. No.	Parts No.	Description	品名	Amt. Req.
1	P13-1	Belt Pulley Cover	皮帶輪蓋	1
2	P13-2	Screw (M4-0.7X8)	螺絲	3
3	P13-3	Washer	墊片	3
4	P13-4	Gear Wheel	齒輪	1
5	P13-5	Gear Wheel	齒輪	1
6	P13-6	Screw (M6-1X6)	螺絲	4
7	P13-7	Synchroniser	定位感應器	1
8	P13-8	Screw (11/64x2)	螺絲	1
9	P13-9	Synchroniser Place	定位感應器座	1
10	P13-10	Screw (M4-0.7x8)	螺絲	6
11	P13-11	Handwheel	馬達手輪	1
12	P13-12	Screw (M5-0.8X5)	螺絲	2
13	P13-13	Timing Belt	皮帶	1
14	P13-14	Screw (M5-0.8X14)	螺絲	4
15	P13-15	Screw (M6-1X15)	螺絲	7
16	P13-16	Washer	墊片	7
17	P13-17	Mini Servomotor Support (Upper)	伺服馬達座(上)	1
18	P13-18	Mini Servomotor	伺服馬達	1
19	P13-19	Mini Servomotor Support (Lower)	伺服馬達座(下)	1
20	P13-20	Washer	墊片	2
21	P13-21	Spring Washer	彈簧墊片	2
22	P13-22	Screw (3/8-16X45)	螺絲	2
23	P13-23	Nut	螺帽	1
24	P13-24	Sewing Maching Supprting Block Cover	機座蓋	1
25	P13-25	Pierce Filament Illustration	穿線圖	1
26	P13-26	Emblem	銘牌	1
27	P13-27	Rivet	鉚釘	2
28	P13-28	Sewing Maching Supprting Block	機座	1
29	P13-29	Pitman	馬達吊桿	1
30	P13-30	Wood Screw	木螺絲	7
31	P13-31	Control Rapid Box	控速器	1
32	P13-32	Control Box	控制箱	1
33	P13-33	Cord Clamp	膠墊	1
34	P13-34	Mini Servomotor, C. Set	伺服馬達	1
35	P13-35	Gear Wheel, C. Set	齒輪組	1
36	P13-36	Gear Wheel, C. Set	齒輪組	1
37	P13-37	Band (12cm)	束帶(12公分)	1
38	P13-38	Screw (3/8-16X50)	螺絲	1
39	P13-39	Arrow Sticker	箭頭貼紙	1
40	P13-40	Oil Seal Plug	膠墊	1

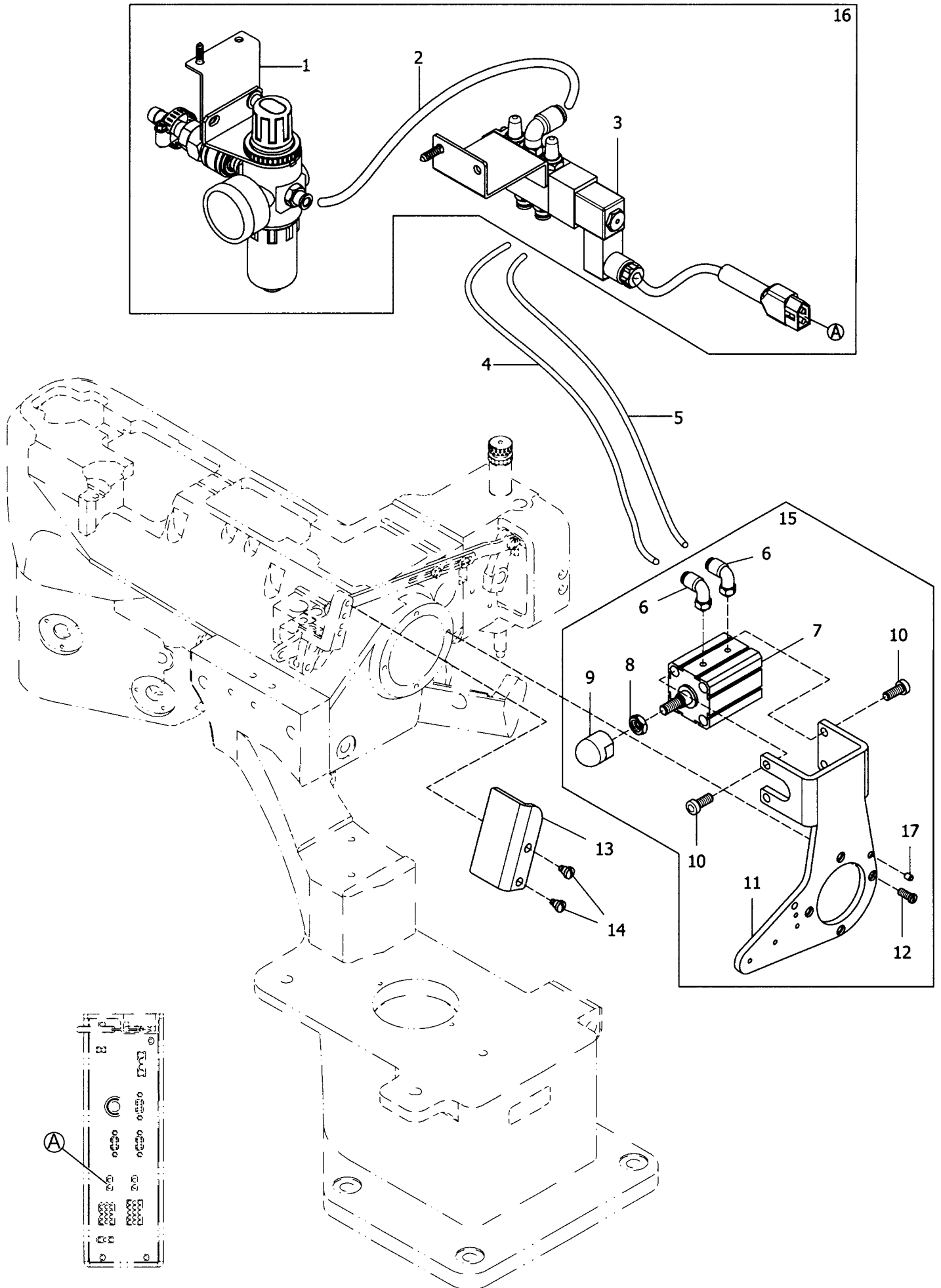

Ref. No.	Parts No.	Description	品 名	Amt. Req.
1	P14-1	Regulator	氣壓錶	1
2	P14-2	Air Tube(6x4mm)	風管(6x4mm)	1
3	P14-3	Solenoid Valve	電磁閥	1
4	P14-4	Air Tube(4x2.5mm)(Blue)	風管(4x2.5)(藍)	1
5	P14-5	Air Tube(4x2.5mm)(Orange)	風管(4x2.5)(橘)	1
6	P14-6	L" Connector	L"形風管接頭	2
7	P14-7	Air Cylinder	氣缸	1
8	P14-8	Nut	螺帽	1
9	P14-9	Presser Lifter Holder	氣缸壓頭	1
10	P14-10	Screw (M6-1X15)	螺絲	4
11	P14-11	Cylinder Bracket	氣缸座	1
12	P14-12	Screw (3/16-32X11.5)	螺絲	4
13	P14-13	Presser Foot Connecting Lever	抬壓腳連桿	1
14	P14-14	Screw (3/16-32X4)	螺絲	2
15	P14-15	Air Cylinder, C. Set	氣缸組	1
16	P14-16	Solenoid Valve, C. Set	電磁閥組	1
17	P14-17	Oil Seal Plug	膠墊	1

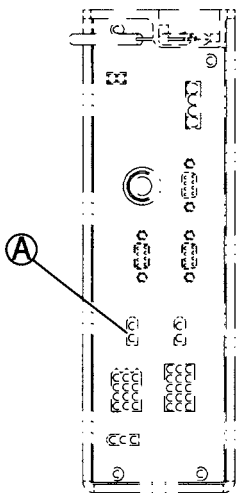
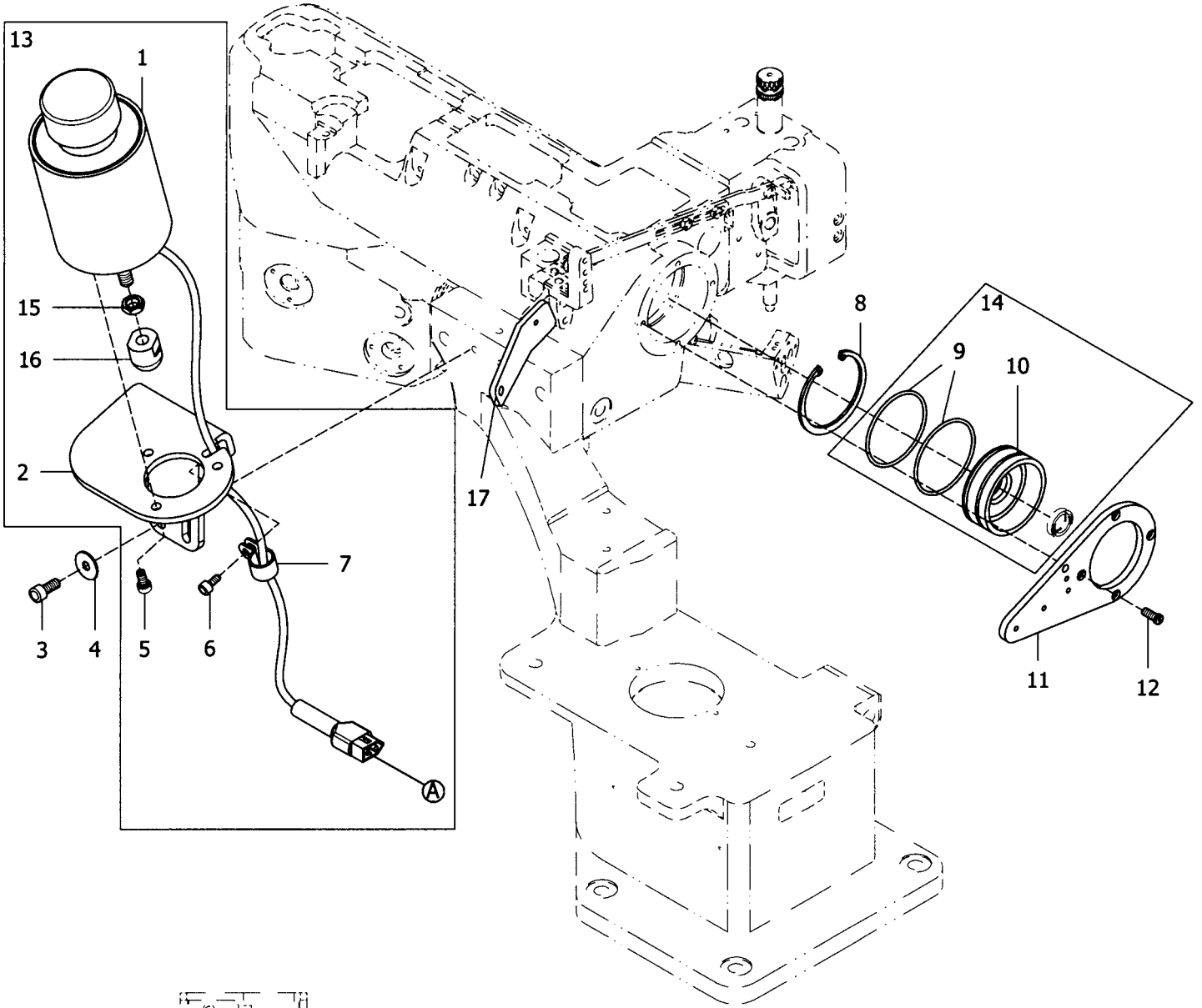

Ref.	Parts			Amt.
No.	No.	Description	品 名	Req.
1	P15-1	Solenoid Valve	電磁閥	1
2	P15-2	Solenoid Valve Bracket	電磁閥座	1
3	P15-3	Screw (M6-1X15)	螺絲	2
4	P15-4	Washer	墊片	2
5	P15-5	Screw (M5-0.8X14)	螺絲	3
6	P15-6	Screw (M4-0.7X8)	螺絲	1
7	P15-7	Cord Clamp	線套	1
8	P15-8	Retaining Ring	扣環	1
9	P15-9	O-Ring	O形橡膠環	2
10	P15-10	Bearing Housing	軸承固定室	1
11	P15-11	Belt Pulley Cover Bracket	皮帶輪蓋座	1
12	P15-12	Screw (3/16-32X11.5)	螺絲	4
13	P15-13	Solenoid Valve, C. Set	電磁閥組	1
14	P15-14	Bearing Housing, C. Set	軸承固定室組	1
15	P15-15	Nut	螺帽	1
16	P15-16	Presser Lifter Holder	氣缸壓頭	1
17	P15-17	Presser Foot Connecting Lever	抬壓腳連桿	1

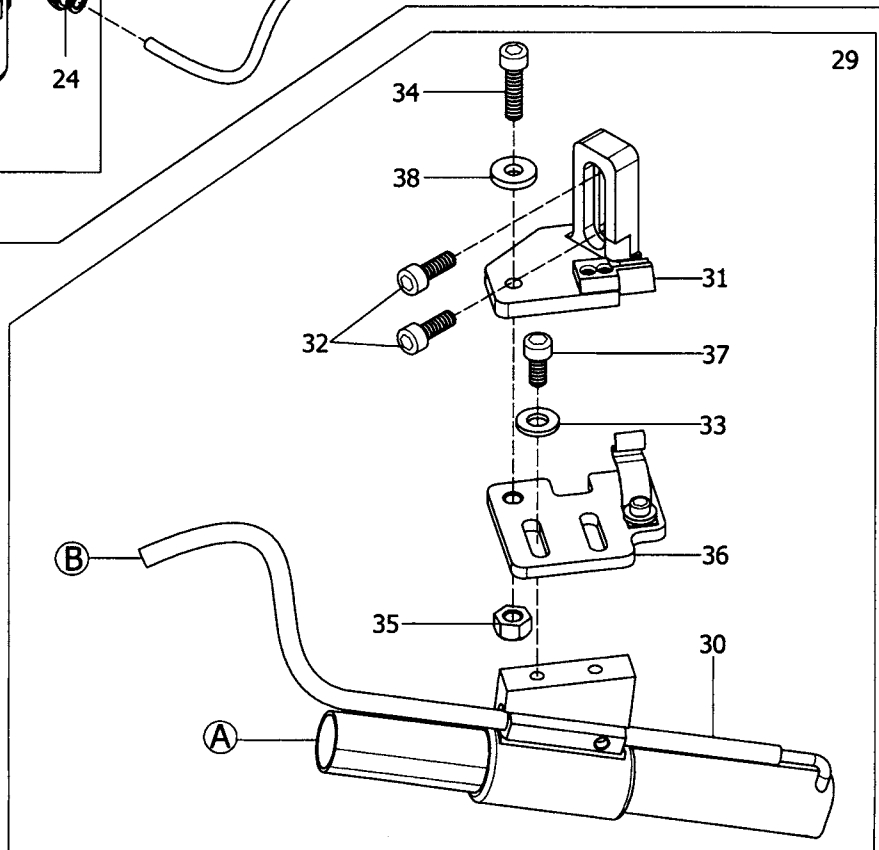
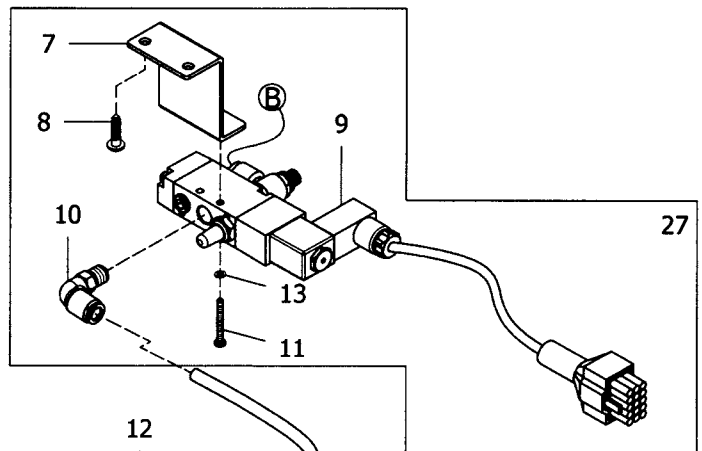
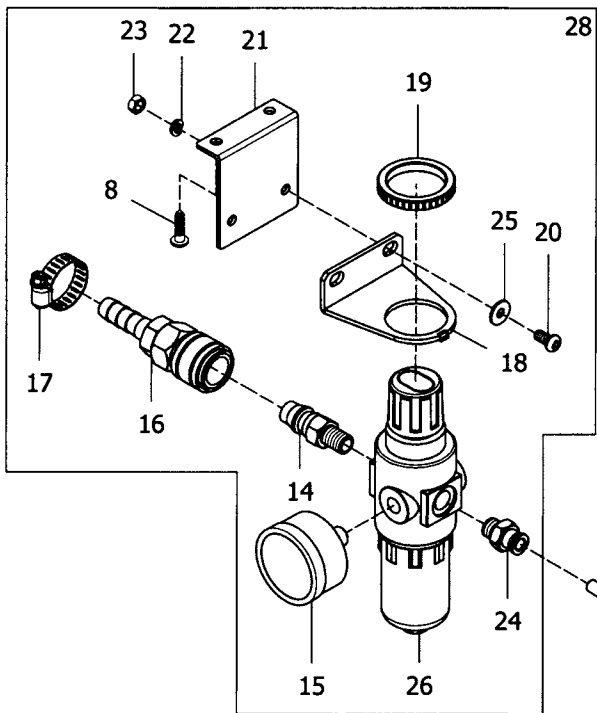
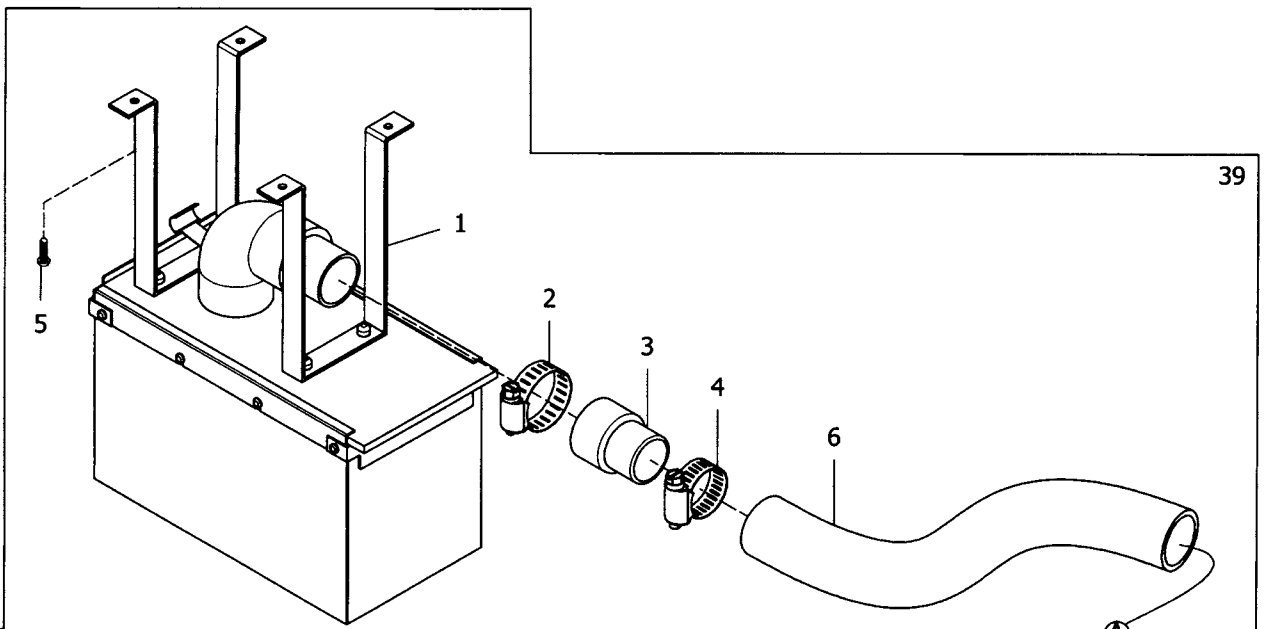

Ref.	Parts			Amt.
No.	No.	Description	品名	Req.
1	P16-1	Dust-Collecting Equipment	集塵袋	1
2	P16-2	Hose Band	束套	1
3	P16-3	Take Over	接管	1
4	P16-4	Hose Band	束套	1
5	P16-5	Wood Screw	木螺絲	4
6	P16-6	Take Over	接管	1
7	P16-7	Regulator Support	固定座	1
8	P16-8	Wood Screw	木螺絲	2
9	P16-9	Solenoid Valve	電磁閥	1
10	P16-10	L" Connector	L"形風管接頭	1
11	P16-11	Screw (M3-0.5X24)	螺絲	2
12	P16-12	Air Tube(6x4mm)	風管(6x4mm)	1
13	P16-13	Spring Washer	彈簧墊片	2
14	P16-14	Hose Union	風管接頭	1
15	P16-15	Regulator	氣壓錶	1
16	P16-16	Hose Union	風管接頭	1
17	P16-17	Hose Band	束套	1
18	P16-18	Regulator Support	固定座	1
19	P16-19	Regulator Support	氣壓錶固定牙套	1
20	P16-20	Screw (M5-0.8X9)	螺絲	2
21	P16-21	Regulator Support	固定座	1
22	P16-22	Spring Washer	彈簧墊片	2
23	P16-23	Nut	螺帽	2
24	P16-24	Connector	風管接頭	1
25	P16-25	Washer	墊片	2
26	P16-26	A Gas Cylinder	氣瓶	1
27	P16-27	Solenoid Valve, C. Set	電磁閥組	1
28	P16-28	Regulator, C. Set	氣壓錶組	1
29	P16-29	Suction Pipe Unit, C. Set	吸管組	1
30	P16-30	Suction Pipe Unit	吸管	1
31	P16-31	Suction Pipe Unit Support (Upper)	吸管固定座(上)	1
32	P16-32	Screw (M5-0.8X14)	螺絲	2
33	P16-33	Washer	墊片	2
34	P16-34	Screw (M5-0.8X15.9)	螺絲	1
35	P16-35	Nut	螺帽	1
36	P16-36	Suction Pipe Unit Support (Lower)	吸管固定座(下)	1
37	P16-37	Screw (M5-0.8X11.7)	螺絲	2
38	P16-38	Washer	墊片	1
39	P16-39	Suction Pipe Unit, C. Set	整組	1

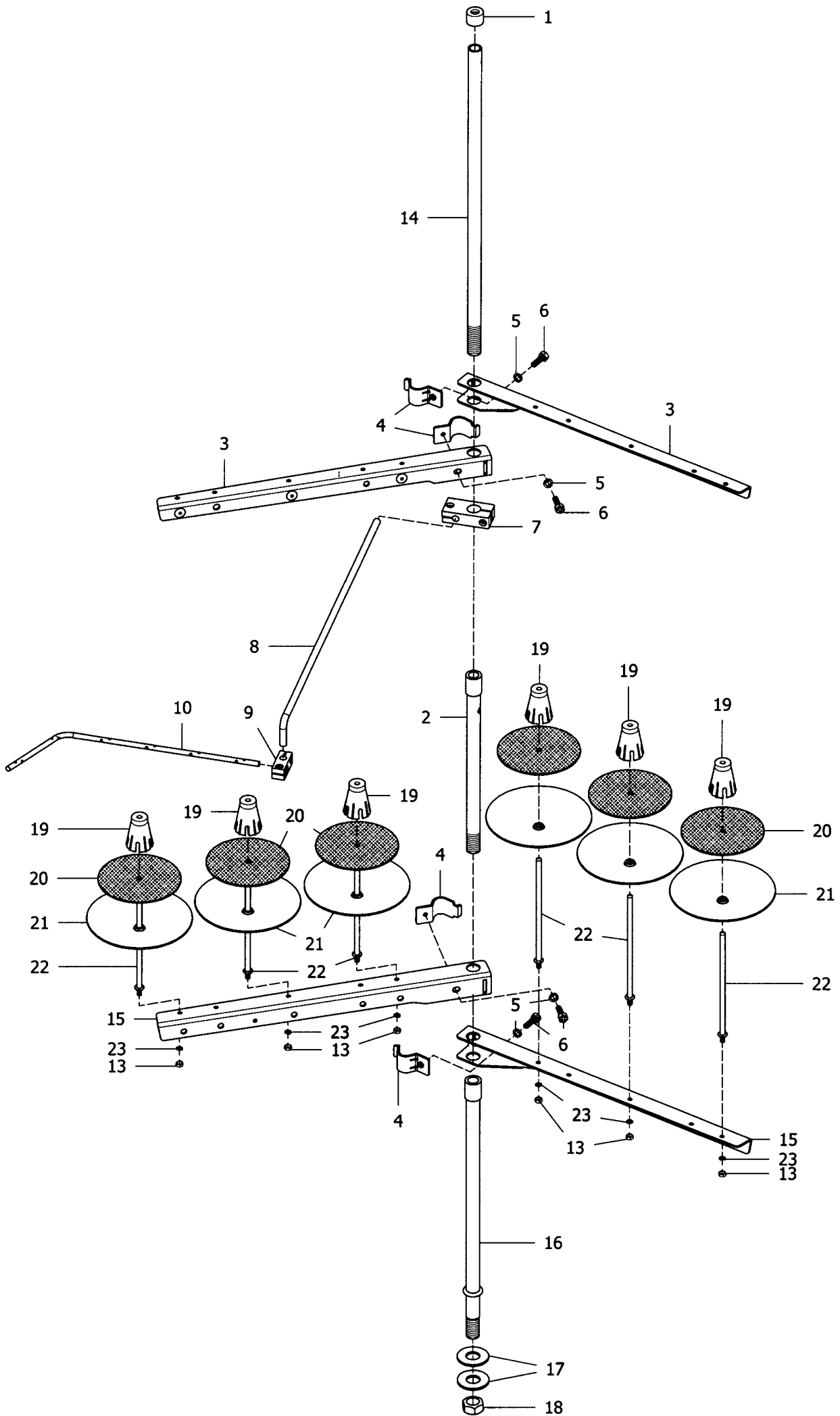

Ref. No.	Parts No.	Description	品 名	Amt. Req.
1	P17-1	Column Cap	柱頭蓋	1
2	P17-2	Column Pipe(Upper)(Short)	上線柱(短)	1
3	P17-3	Thread Hanger (3 Spools Type)	3孔過線吊臂	2
4	P17-4	Thread Hanger Support	過線吊桿固定座	4
5	P17-5	Spring Washer	彈簧墊片	4
6	P17-6	Screw (M6-1X23)	螺絲	4
7	P17-7	Thread Guide Holder (Large)	大過線桿固定座	1
8	P17-8	Thread Guide Arm	過線桿連接臂	1
9	P17-9	Thread Guide Holder (Small)	小過線桿固定座	1
10	P17-10	Thread Guide (6 Spool Type)	6孔過線桿	1
11	P17-13	Nut	螺帽	6
12	P17-14	Column Pipe(Upper)	上線柱	1
13	P17-15	Spool Stand (3 Spool Type)	3孔線軸架	2
14	P17-16	Column Pipe (Lower)	下線柱	1
15	P17-17	Washer	墊片	2
16	P17-18	Nut	螺帽	1
17	P17-19	Spool Cushion	線軸避震座	6
18	P17-20	Spool Mat	線軸墊	6
19	P17-21	Spool Seat Disc	線軸底盤	6
20	P17-22	Spool Pin	線軸柱	6
21	P17-23	Spring Washer	彈簧墊片	6

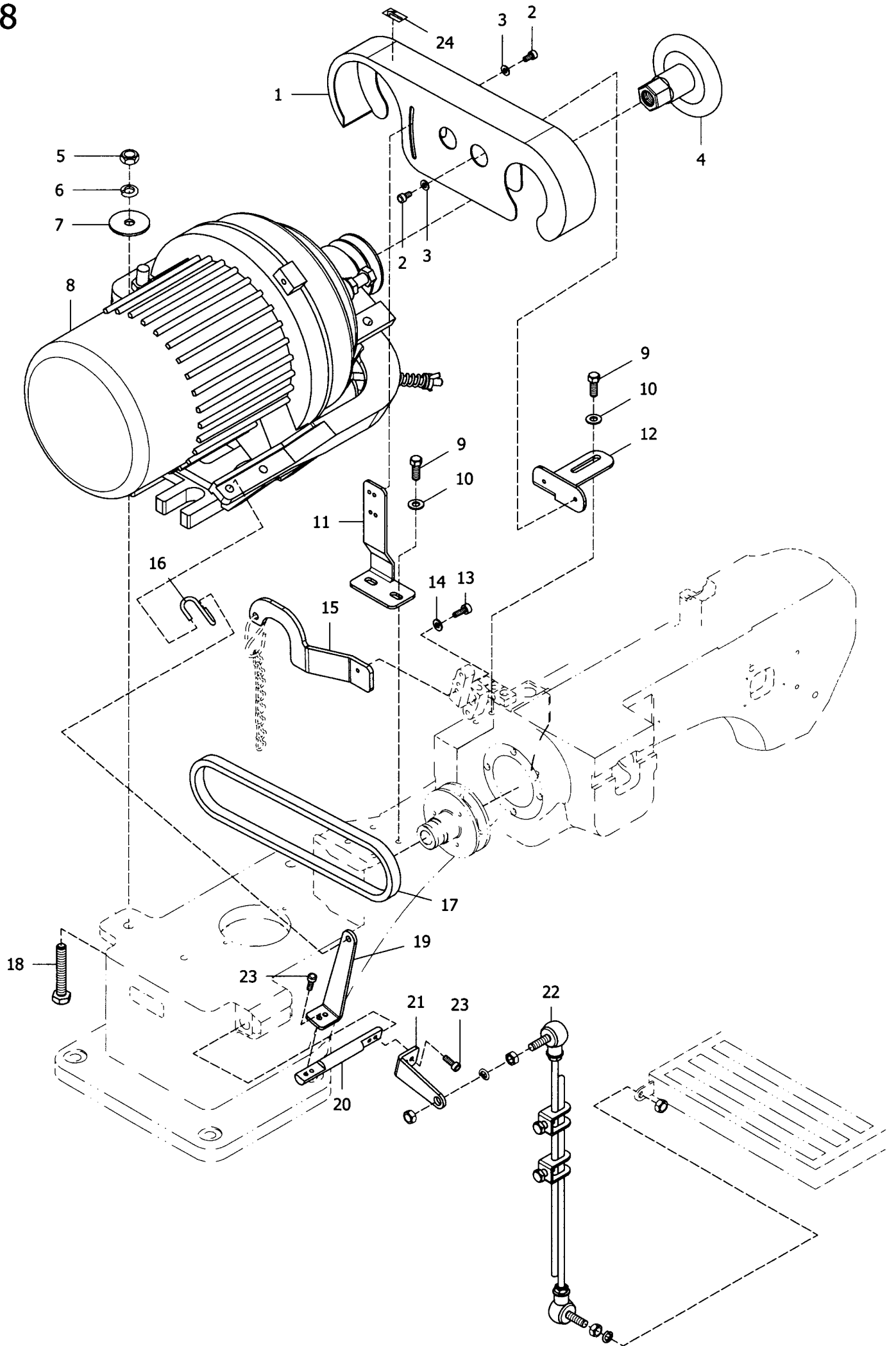

Ref.	Parts			Amt.
No.	No.	Description	品 名	Req.
1	P18-1	Belt Pulley Cover	皮帶輪蓋	1
2	P18-2	Screw (M4-0.7X5)	螺絲	4
3	P18-3	Washer	墊片	4
4	P18-4	Handwheel	馬達手輪	1
5	P18-5	Nut	螺帽	3
6	P18-6	Spring Washer	彈簧墊片	3
7	P18-7	Washer	墊片	3
8	P18-8	Motor	馬達	1
9	P18-9	Screw (M6-1X15)	螺絲	4
10	P18-10	Washer	墊片	4
11	P18-11	Belt Pulley Cover Bracket (Down)	皮帶輪蓋支撐架(下)	1
12	P18-12	Belt Pulley Cover Bracket (Upper)	皮帶輪蓋支撐架(上)	1
13	P18-13	Screw (M4-0.7X8)	螺絲	1
14	P18-14	Washer	墊片	1
15	P18-15	Presser Foot Connecting Lever	抬壓腳連桿	1
16	P18-16	Iron Hook	鐵勾	1
17	P18-17	Belt	皮帶	1
18	P18-18	Screw (5/16-18X45)	螺絲	3
19	P18-19	Driving Lever(Length)	馬達驅動連接桿(長)	1
20	P18-20	Driving Lever Shaft	連接桿軸心	1
21	P18-21	Driving Lever(Short)	馬達驅動連接桿(短)	1
22	P18-22	Pitman(Length)	馬達吊桿(長)	1
23	P18-23	Screw (M4-0.7X8)	螺絲	4
24	P18-24	Arrow Sticker	箭頭貼紙	1

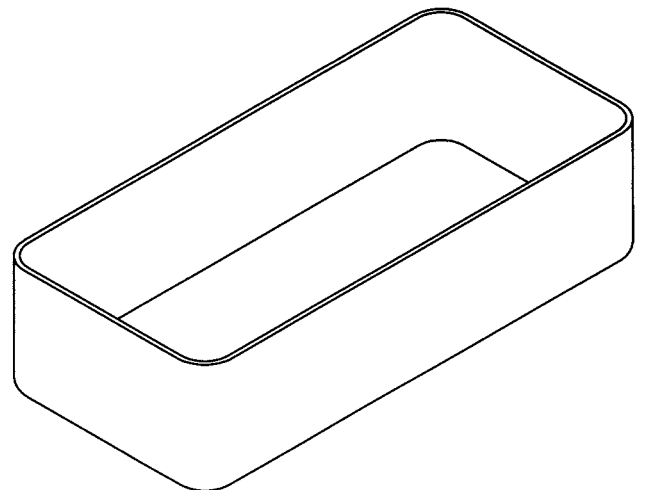
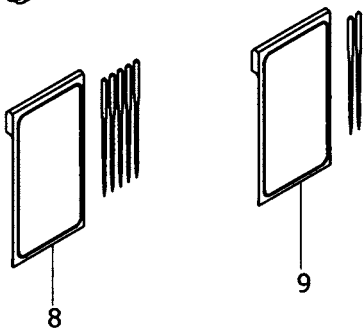
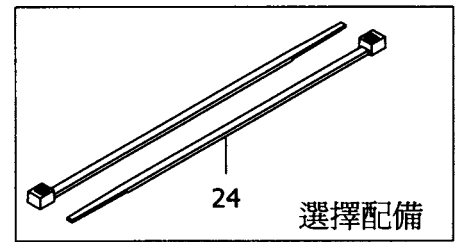
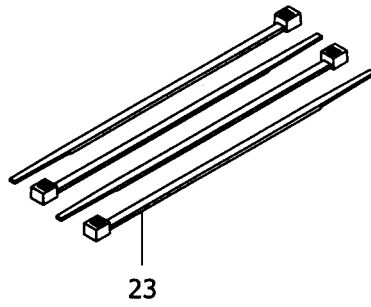
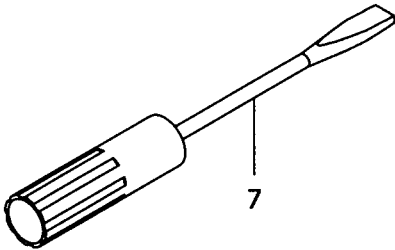
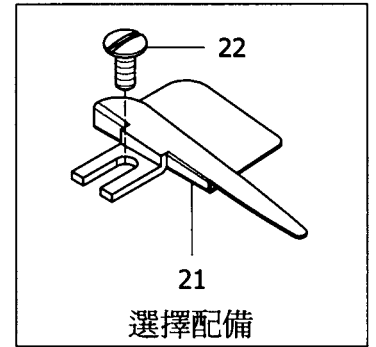
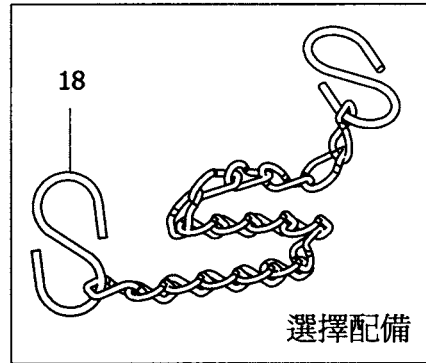
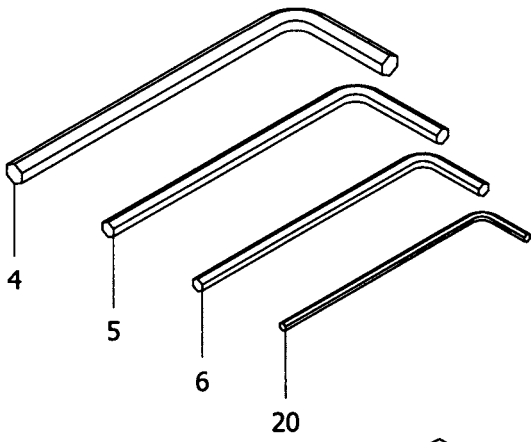
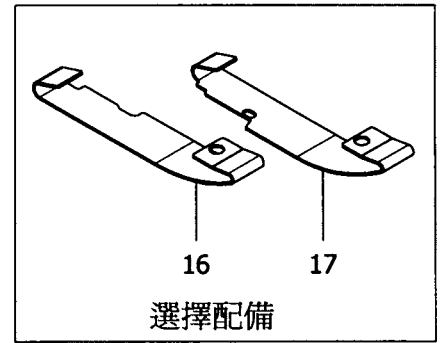
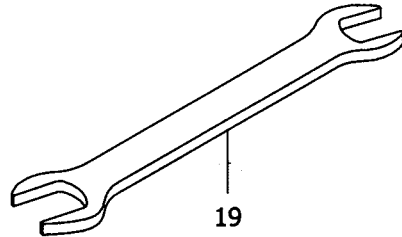
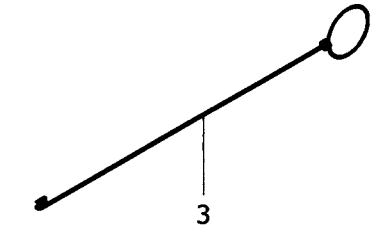
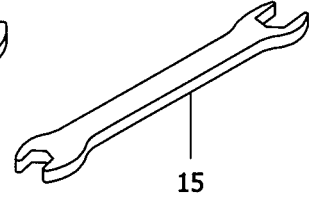
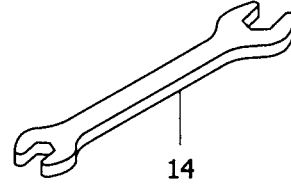
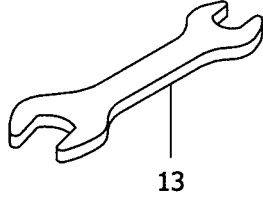
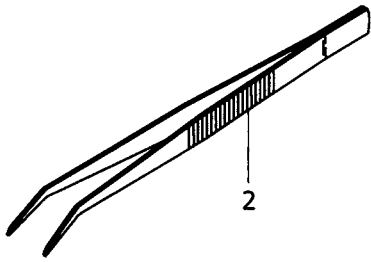
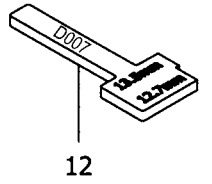
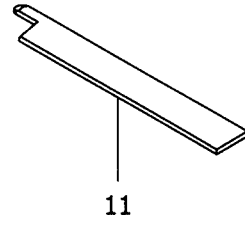
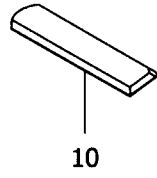
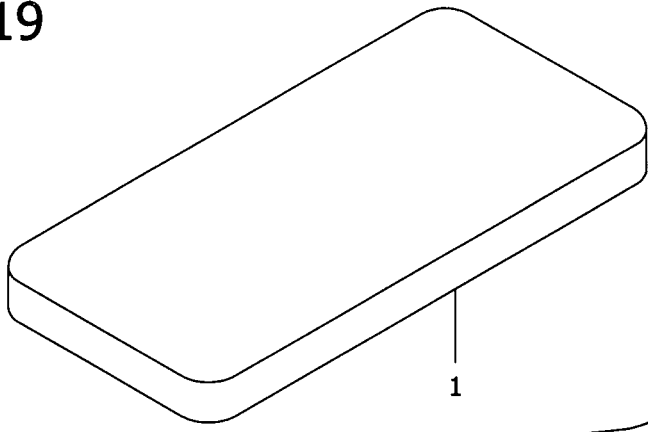

Ref. No.	Parts No.	Description	品名	Amt. Req.
1	P19-1	Attachment Box	附件盒	1
2	P19-2	Thread Tweezers	穿線夾	1
3	P19-3	Threading Wire	穿線鐵絲	1
4	P19-4	Hexagonal Wrench (4mm)	內六角板手(4mm)	1
5	P19-5	Hexagonal Wrench (3mm)	內六角板手(3mm)	1
6	P19-6	Hexagonal Wrench (2.5mm)	內六角板手(2.5mm)	1
7	P19-7	Screwdriver	螺絲起子	1
8	P19-8	Needle	擊針	5
9	P19-9	Needle	擊針	2
10	P19-10	Lower Knife	下切刀片	1
11	P19-11	Upper Knife	上切刀片	1
12	P19-12	Needle Height Gauge	針棒高度調節器	1
13	P19-13	Wrench	板手	1
14	P19-14	Wrench	板手	1
15	P19-15	Wrench	板手	1
16	P19-16	Double Side Cut Presser Foot Spring Plate (Left)	雙切壓腳彈簧片(左)	1
17	P19-17	Double Side Cut Presser Foot Spring Plate (Right)	雙切壓腳彈簧片(右)	1
18	P19-18	Iron Chain	鐵鍊	1
19	P19-19	Wrench	板手	1
20	P19-20	Hexagonal Wrench (1.5mm)	內六角板手(1.5mm)	1
21	P19-21	Folder	導布器	1
22	P19-22	Screw(1/8-44X8)	螺絲	1
23	P19-23	Band (12cm)	束帶(12公分)	4
24	P19-24	Band (15cm)	束帶(15公分)	2

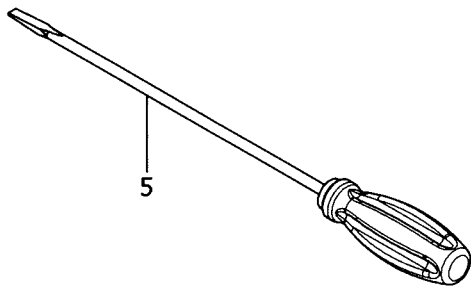
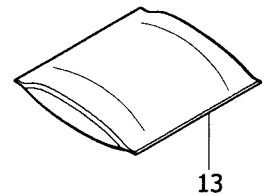
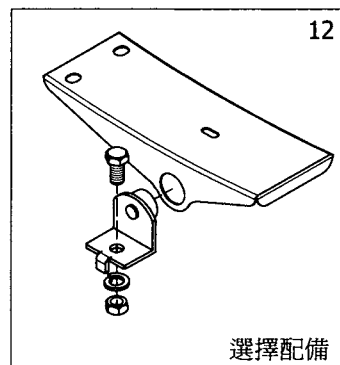
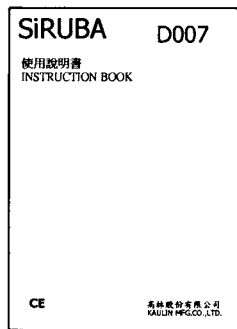
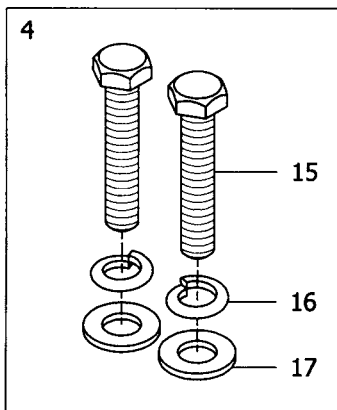
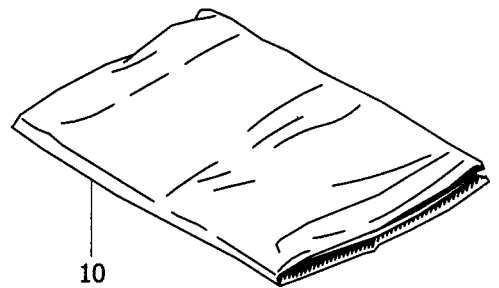
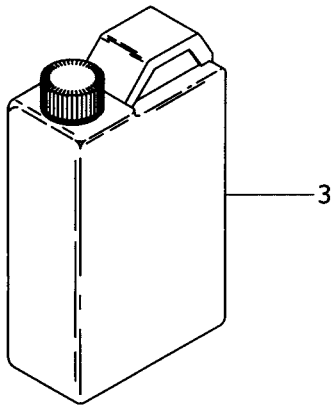
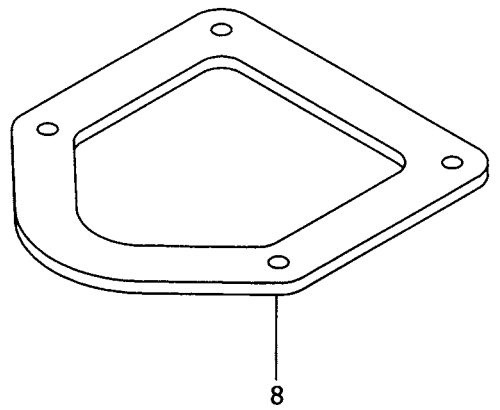
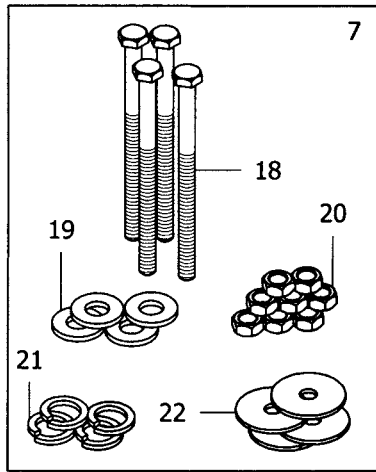
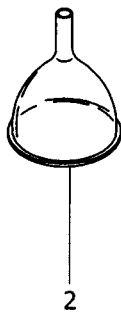

11

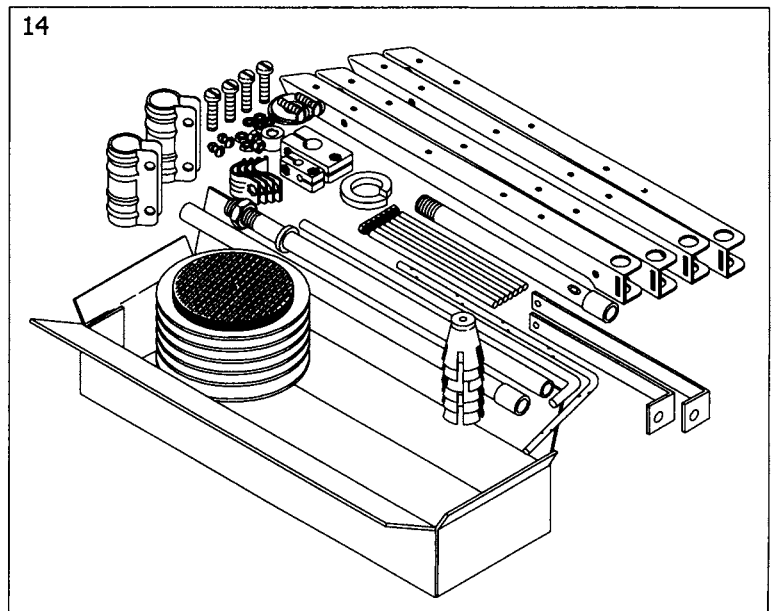
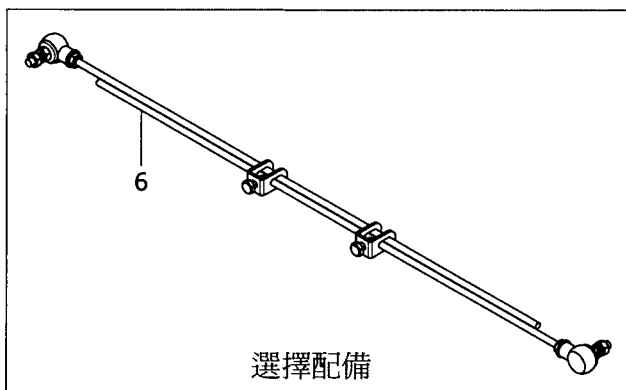

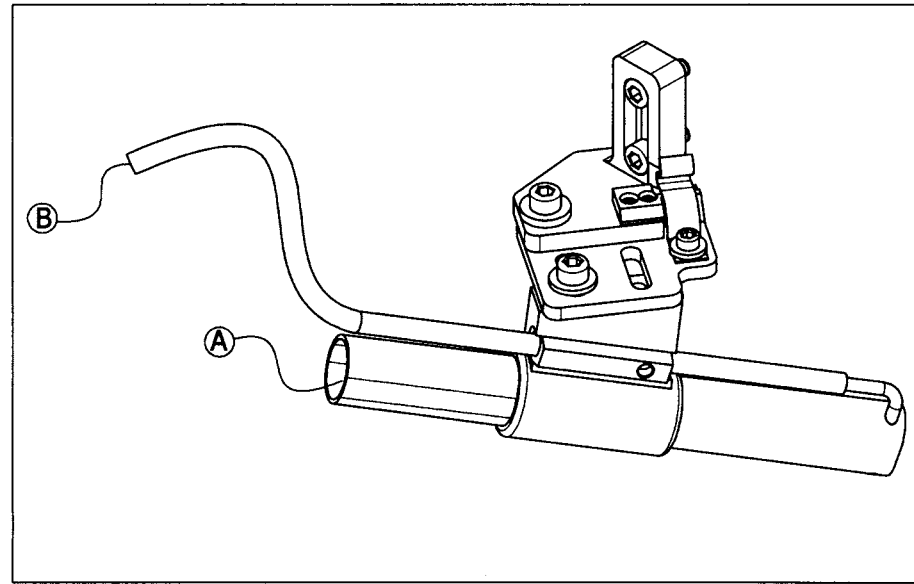
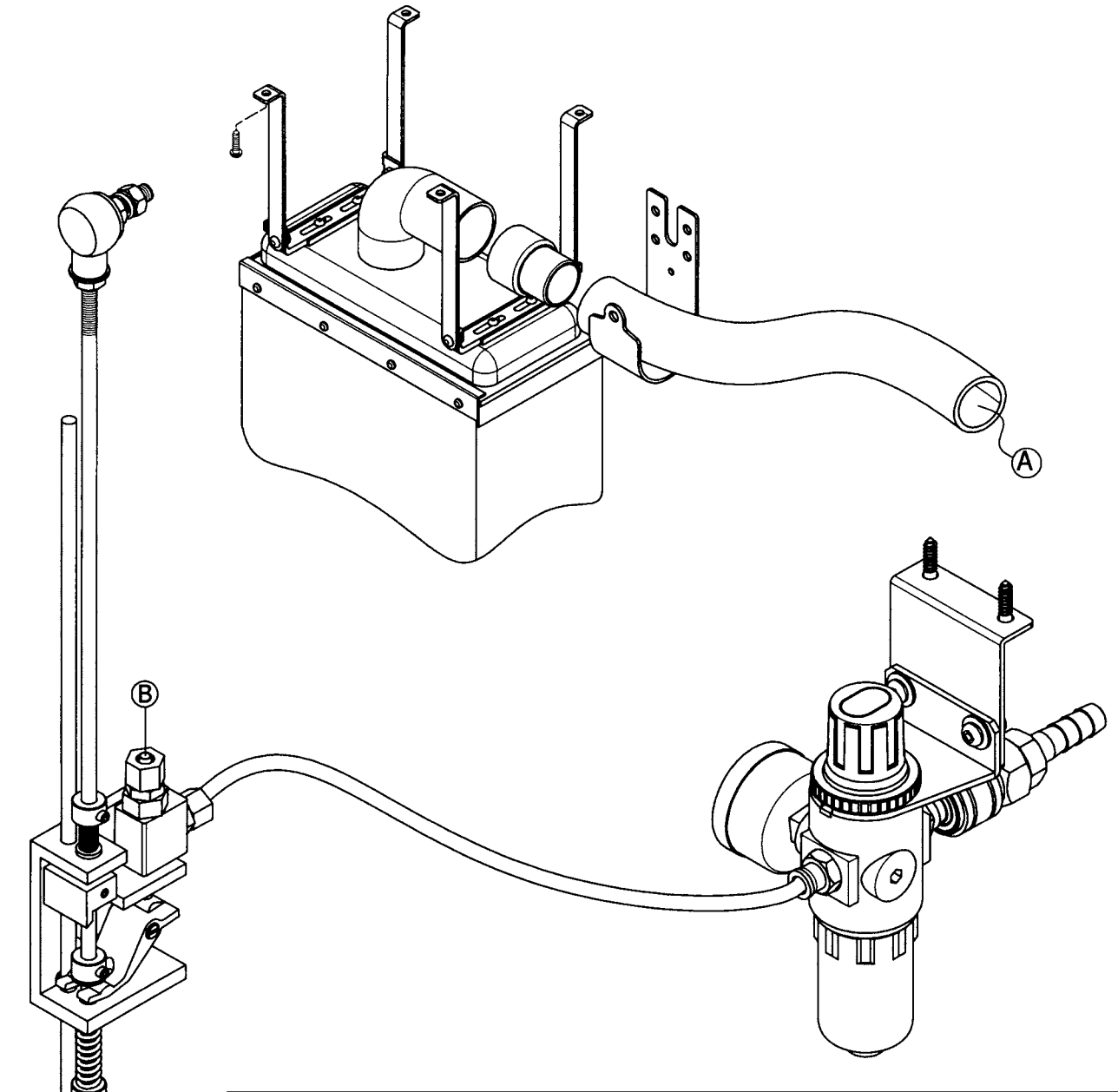

Ref. No.	Parts No.	Description	品 名	Amt. Req.
1	P20-1	Oiler	油壺	1
2	P20-2	Funnel	漏斗	1
3	P20-3	Oil	潤滑油	1
4	P20-4	Screw, C. Set	螺絲組	1
5	P20-5	Screwdriver	螺絲起子	1
6	P20-6	Pitman(Length)	馬達吊桿(長)	1
7	P20-7	Screw, C. Set	螺絲組	1
8	P20-8	Supporting Block Rubber Cushion	車台固定座避震膠墊	1
9	P20-9	Parts Book	零件本	1
10	P20-10	Machine Cover	防塵罩	1
11	P20-11	Instruction Book	維修手冊	1
12	P20-12	Pedal, C. Set	壓腳踏板組	1
13	P20-13	Drier	乾燥劑	1
14	P20-14	Thread Stand, C. Set	線架組	1
15	P20-15	Screw(3/8-16X45)	螺絲	2
16	P20-16	Spring Washer	彈簧墊片	2
17	P20-17	Washer	墊片	2
18	P20-18	Screw(5/16-18X100)	螺絲	4
19	P20-19	Washer	墊片	4
20	P20-20	Nut	螺帽	8
21	P20-21	Spring Washer	彈簧墊片	4
22	P20-22	Washer	墊片	4



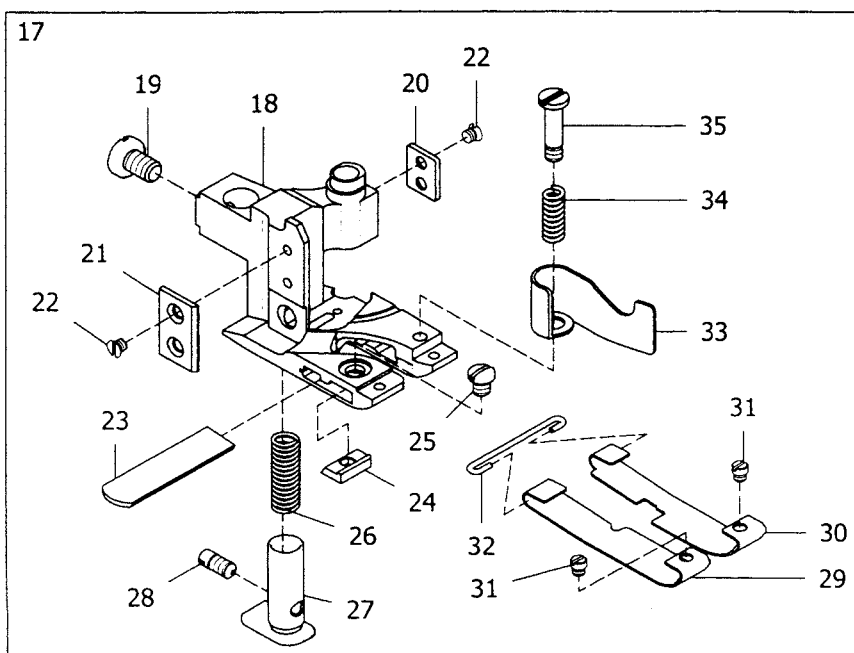
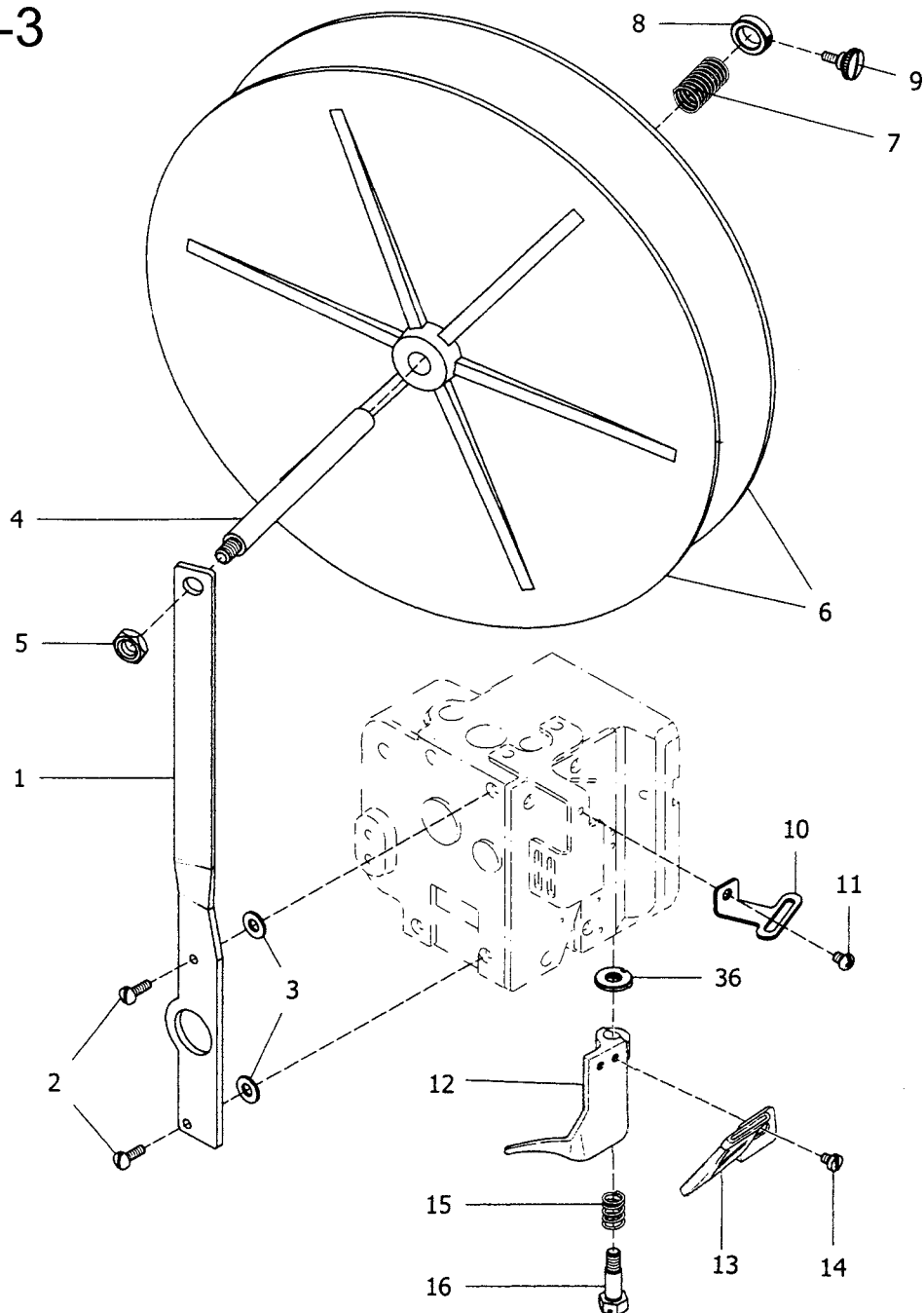



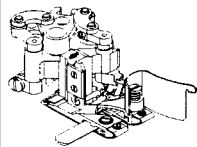
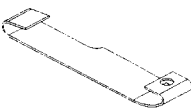
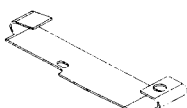

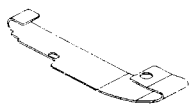
Ref.	Parts			Amt.
<u>No.</u>	<u>No.</u>	<u>Description</u>	<u>品名</u>	<u>Req.</u>
1	P21-1	Suction Pipe Unit, C. Set	吸布層整組	1
2	P21-2	Suction Pipe Unit, C. Set	吸管組	1

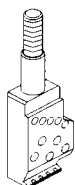
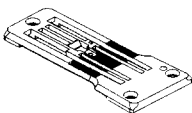
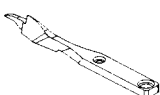
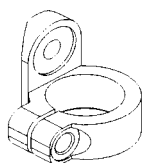
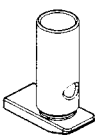

Ref.	Parts			Amt.
<u>No.</u>	<u>No.</u>	<u>Description</u>	<u>品 名</u>	<u>Req.</u>
1	P22-1	Tape Reel Support	支撐架	1
2	P22-2	Screw(9/64-40X12)	螺絲	2
3	P22-3	Rubber Cushion	橡膠墊片	2
4	P22-4	Tape Reel Shaft	支撐桿	1
5	P22-5	Nut	螺母	1
6	P22-6	Tape Base	塑膠盤	2
7	P22-7	Tape Reel Spring	彈簧	1
8	P22-8	Collar	軸環	1
9	P22-9	Screw(9/64-40X7.5)	螺絲	1
10	P22-10	Tape Guide	導布片	1
11	P22-11	Screw(M4-0.7X5)	螺絲	1
12	P22-12	Frame Chip Guard	防護蓋	1
13	P22-13	Folder	喇叭	1
14	P22-14	Screw(9/64-40X4.5)	螺絲	2
15	P22-15	Frame Chip Guard Spring	彈簧	1
16	P22-16	Screw(M5-0.8X8.7)	螺絲	1
17	P22-17	Presser Foot, C. Set	壓腳組	1
18	P22-18	Presser Foot	壓腳	1
19	P22-19	Screw(11/64-40X6.3)	螺絲	1
20	P22-20	Presser Foot Attach Piece (Right)	壓整連接片(右)	1
21	P22-21	Presser Foot Attach Piece (Left)	壓整連接片(左)	1
22	P22-22	Screw(3/32-56X1.5)	螺絲	4
23	P22-23	Lower Knife	下切刀	1
24	P22-24	Lower Knife Clamp	下切刀夾板	1
25	P22-25	Screw(1/8-44X3.5)	螺絲	1
26	P22-26	Yielding Secion Spring	小壓具彈簧	1
27	P22-27	Yielding Secion	小壓具	1
28	P22-28	Screw(1/8-44X5)	螺絲	1
29	P22-29	Presser Foot Spring Plate (Left)	壓腳彈簧片(左)	1
30	P22-30	Presser Foot Spring Plate (Right)	壓腳彈簧片(右)	1
31	P22-31	Screw(3/32-56X2)	螺絲	2
32	P22-32	Spring Plate Holder	彈簧片固定鐵勾	1
33	P22-33	Chip Guard	切角防護片	1
34	P22-34	Chip Guard Spring	切角防護片彈簧	1
35	P22-35	Screw(1/8-44X3.4)	螺絲	1
36	P22-36	Frame chip Guard Washer	墊片	1

Main Parts					
	Models	押具整組	押具押板(左)	押具押板(右)	押具押板(左)
D007-01-452	P6-14(452)	P6-36	P6-37(452)	P6-47	P6-48(452)
D007-02-452	P12-1(452)	P12-24	P12-25	P12-43	P12-44
D007-01-460	P6-14(460)	P6-36	P6-37(460)	P6-47	P6-48(460)
D007-02-460	P12-1(460)	P12-24	P12-25	P12-43	P12-44
D007H-01-452	P6-14(452)	P6-36	P6-37(452)		
D007H-02-452	P12-1H(452)	P12-24H	P12-25H		
D007H-01-460	P6-14(460)	P6-36	P6-37(460)		
D007H-02-460	P12-1H(460)	P12-24H	P12-25H		
D007-03-452	P22-17	P22-29	P22-30		
D007-03-460	"	"	"		

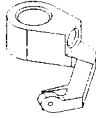
Main Parts					
	Models	針鏢	針板	導布器	勾夾襯套
D007-01-452	P5-40(452)	P5-44(452)		P7-7	P6-34
D007-02-452	"	P12-42(452)	P12-31	"	P12-21
D007-01-460	P5-40(460)	P5-44(460)		"	P6-34
D007-02-460	"	P12-42(460)	P12-31	"	P12-21
D007H-01-452	P5-40(452)	P5-44(452)		"	P6-34
D007H-02-452	"	P12-42(452)	P12-31H	"	P12-21
D007H-01-460	P5-40(460)	P5-44(460)		"	P6-34
D007H-02-460	"	P12-42(460)	P12-31H	"	P12-21
D007-03-452	P5-40(452)	P5-44(452)		"	P22-27
D007-03-460	P5-40(460)	P5-44(460)		"	"

					
上刀片	下刀片	下刀夾板	上飾線勾針(短)	上飾線勾針(長)	導布板
P7-42	P7-40	P6-31	P6-25	P6-22	
//	//	P12-18	P12-12	P12-9	P12-22
//	//	P6-31	P6-27	P6-24	
//	//	P12-18	P12-12	P12-9	P12-22
P7-42H	//	P6-31	P6-25	P6-22	
//	//	//	P12-12	P12-9	P12-22H
//	//	//	P6-25	P6-22	
//	//	//	P12-12	P12-9	P12-22H
P7-42	P22-23	P22-24			
//	//	//			

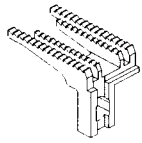
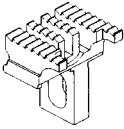
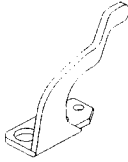
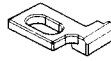
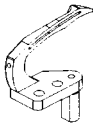
					
針板舌	前送齒	後送齒	針檔(前)	針檔(後)	下飾線勾針
P5-45(452)	P10-7	P10-8	P8-45	P10-10	P8-43
//	//	P12-41	//	//	//
P5-45(460)	//	P10-8	//	//	//
//	//	P12-41	//	//	//
P5-45(452)	P10-54	P10-53	//	//	//
//	P12-56	P12-55	//	//	//
P5-45(460)	P10-54	P10-53	//	//	//
//	P12-56	P12-55	//	//	//
P5-45(452)	P10-7	P10-8	//	//	//
P5-45(460)	//	//	//	//	//



D007

高林股份有限公司 KAULIN MFG. CO., LTD.